

PORTFOLIO PDF

Laith Wattar Project Portfolio

Main project cards are followed by their detailed sub-slides, images, and bullet points.

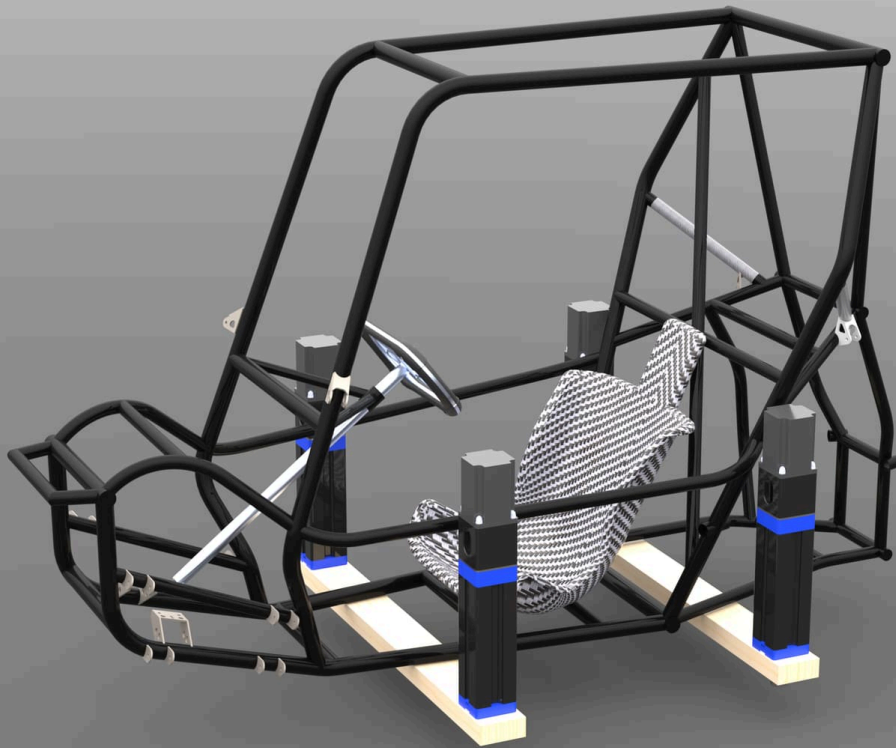

MAIN PROJECT CARD

BAJA SAE Motion Sim

Motion simulation platform designed for Baja SAE driver development using custom actuators, STM32 controls, and real-time telemetry integration.

VIEW YOUTUBE VIDEO

<https://www.youtube.com/watch?v=-549WYZ5cbQ>

DETAIL 1 OF 9

Full Motion Simulator Demo

- I recieved a grant from the world-renowned Sears think[box] to construct my project
- The attached video demonstrates the completed simulator running with live driving inputs
- It uses custom linear actuators mounted to the CWRU BAJA SR21 frame
- It also integrates STM32-based control hardware with racing telemetry
- I built this for training drivers without causing wear on the real car components



DETAIL 2 OF 9

Original SR21 Competition Frame

- Started as a former CWRU Motorsports competition chassis
- I used the existing cockpit as the foundation for the simulator
- Preserved realistic BAJA seating, steering, and driver positioning
- Provided a full-scale platform for driver training

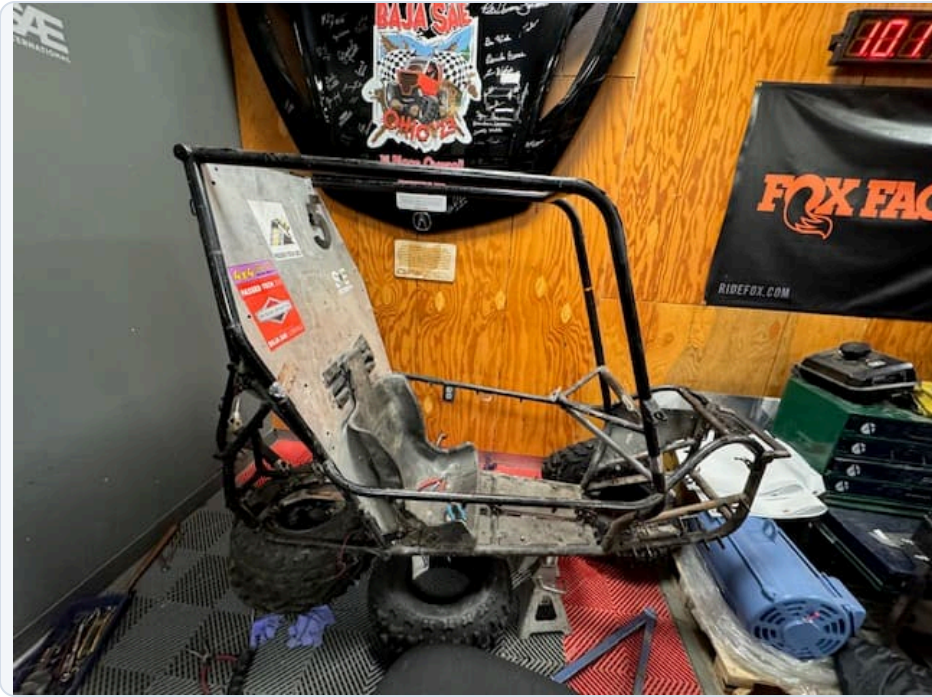
**DETAIL 3 OF 9****Retired Frame Teardown**

- Removed unused and damaged competition components from the chassis
- Evaluated mounting locations for actuators, electronics, and controls
- Prepared the frame for transport back to my house

**DETAIL 4 OF 9****Frame Preparation**

- Removed panels and firewall from the chassis
- Pressure washed the frame to remove leftover mud and grease residue
- Prepped the chassis with primer for repainting

**DETAIL 5 OF 9****Simulator Floor and Steering Base**

- Installed a custom plywood floorboard with metal on top
- Added a plywood base for the steering wheel and electronics
- Began adapting the cockpit for simulator controls
- Established the layout for pedals, steering, and display hardware

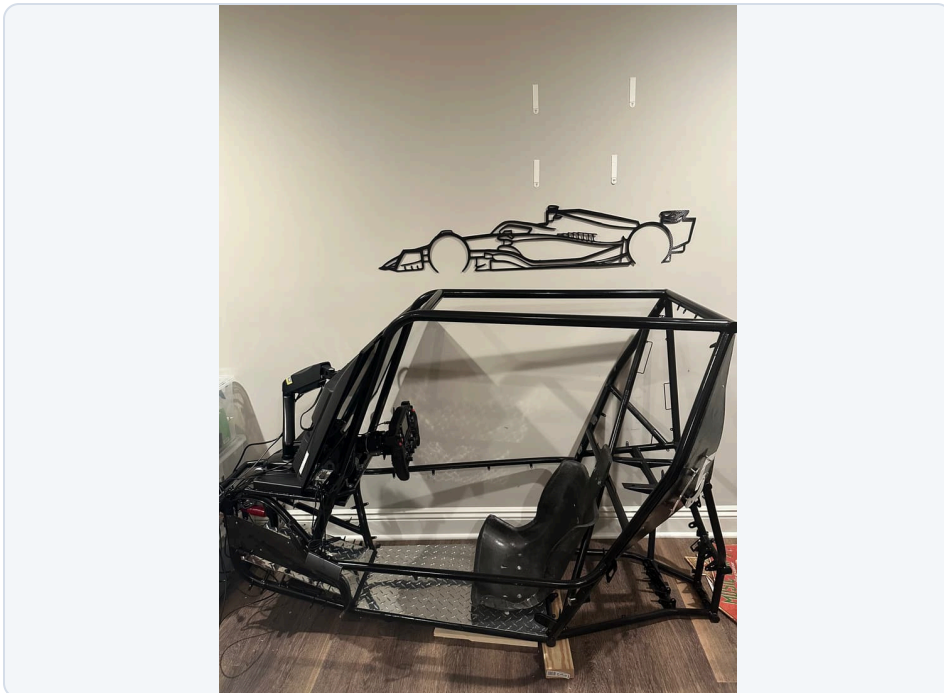
**DETAIL 6 OF 9****Version 1 - Static Simulator**

- Built the first usable driving setup inside the BAJA frame
- Used a single repurposed TV for the display
- Validated seating position and ergonomics
- This version served as the baseline before adding motion and upgraded displays

**DETAIL 7 OF 9****Version 2 - Triple Monitor Upgrade**

- Upgraded from a single display to a triple-monitor layout
- Improved field of view for greater immersiveness
- Created a more realistic visual environment before motion integration

**DETAIL 8 OF 9****think[box] Project Showcase**

- Presented the completed full-motion simulator at think[box]
- Demonstrated the system to students, staff, and visitors
- Showcased custom actuators, controls, and simulator integration
- The Case Alumni Association Director of Communications even gave it a test! 😊

VIEW YOUTUBE VIDEO

<https://www.youtube.com/watch?v=gbVb0tjXpt8>

DETAIL 9 OF 9**Actuator Motion Test**

- Shows actuator response during initial motion testing
- Validates platform movement before final tuning of the PID controller
- Tests the mechanical mounting and travel limits
- Helped identify improvements for speed, stiffness, and reliability



MAIN PROJECT CARD

SR26 Steering Wheel

Second-generation BAJA steering wheel focused on packaging efficiency, manufacturability, and improved driver ergonomics.



DETAIL 1 OF 18

SR26 Steering Wheel Final Design

- Rendered view of the completed SR26 steering wheel installed in the vehicle
- Features 8 Otto P9 push buttons for shock macros, 21 LEDs, 2 thumb potentiometers, 3 RS26 rotary encoders, and 4 rear paddles
- I redesigned the custom driver handles around updated 3D hand scans and introduced modular grip corners. This allows drivers to test different shapes and select their preferred ergonomics for hand-over-hand style steering.
- This generation wheel uses a full carbon fiber front panel with urethane-bonded 3D printed inserts and a 70mm quick release for rapid removal
- The systems team overhauled the UI with expanded message lights and a dedicated debugging mode

Ergonomics

Steering Wheel Updates

- Changed from open-bottom to a smooth closed-bottom design
 - Prevents blisters caused by hands digging into the sharp corner on the bottom of wheel when doing hand-over-hand steering
- The corners of the wheel are separate, modular pieces that can be personalized to the driver's choice
- The grooves on the back of the handles are based on an updated driver 3D hand scan
- The middle section of the handles is now cast using polyurethane and a 3D printed PETG core, allowing for a softer and more comfortable grip compared to last years solid PETG handles

Issue: driver hands developing blisters during endurance races

Analysis: reevaluated wheel shape and handle material

Changes: 3D hand scan updated; soft polyurethane used for grooved section; bottom corner was changed from sharp to curved

Validation: drivers reported no blisters when testing

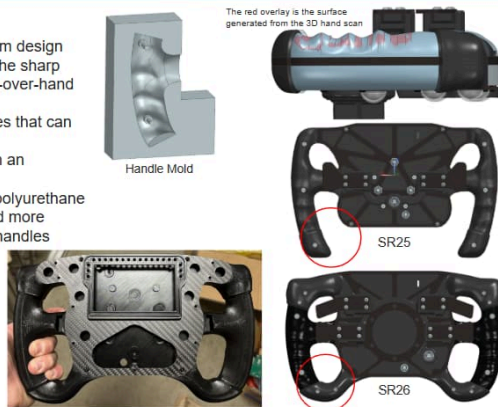

DETAIL 2 OF 18

Ergonomic Development Updates

- Updated handle geometry eliminated driver blistering during endurance events
- Modular grip architecture and improved hand scan integration significantly improved comfort and usability

**DETAIL 3 OF 18****Front Wheel CAD Overview**

- Front CAD render showcasing packaging layout, controls, display system, and updated handle geometry
- Packaging and ergonomics were refined while maintaining aggressive size constraints

**DETAIL 4 OF 18****Rear Architecture and Paddle System**

- Rear view showcasing 4 paddles, modular handles, and 70mm quick release mounting pattern
- I designed the wheel to support both direct steering column mounting for competition and quick-release mounting for off-season testing

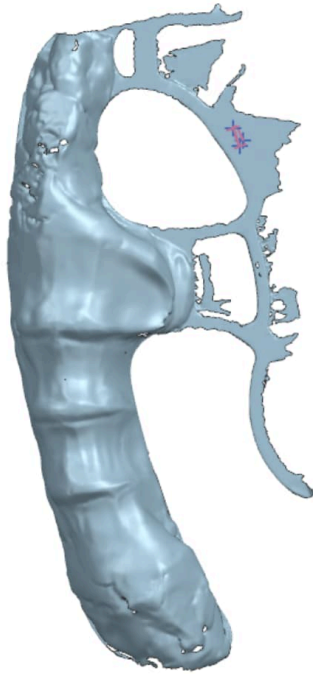
**DETAIL 5 OF 18****Driver Hand Scan**

- Drivers pressed their hands into clay molds which I converted into handle geometry inside Siemens NX
- The scans directly influenced my handle CAD and overall wheel ergonomics

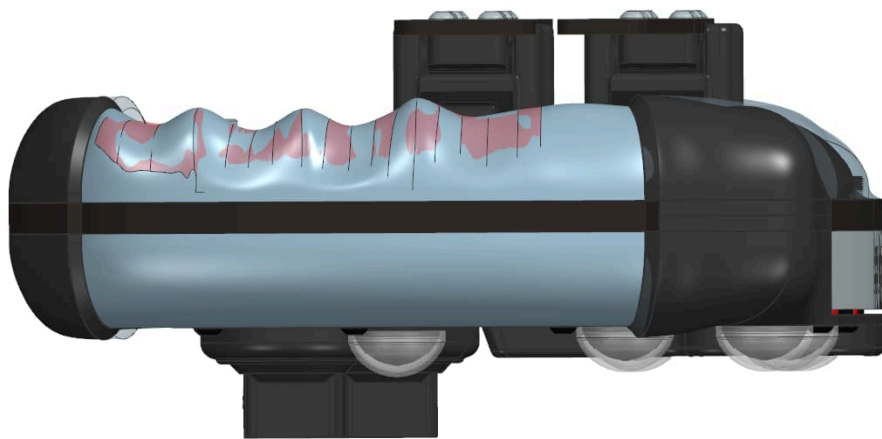
**DETAIL 6 OF 18****Grip Surface Development**

- The red surface represents the hand scan, while the blue surface shows the finished grip geometry
- I built the grip surfaces using splines, G1 continuity constraints, and Through Curve Mesh surfacing
- The steering wheel CAD totaled nearly 2000 features due to the complexity of the surfaces! 🤖

**DETAIL 7 OF 18****Front Electronics Packaging**

- Front CAD view with enclosure removed showcasing packaging
- Only approximately 0.5 inches of internal height was available for the electronics
- I designed PCB mounts and screen attachment mechanisms, and I also added desiccant pods to provide some moisture protection

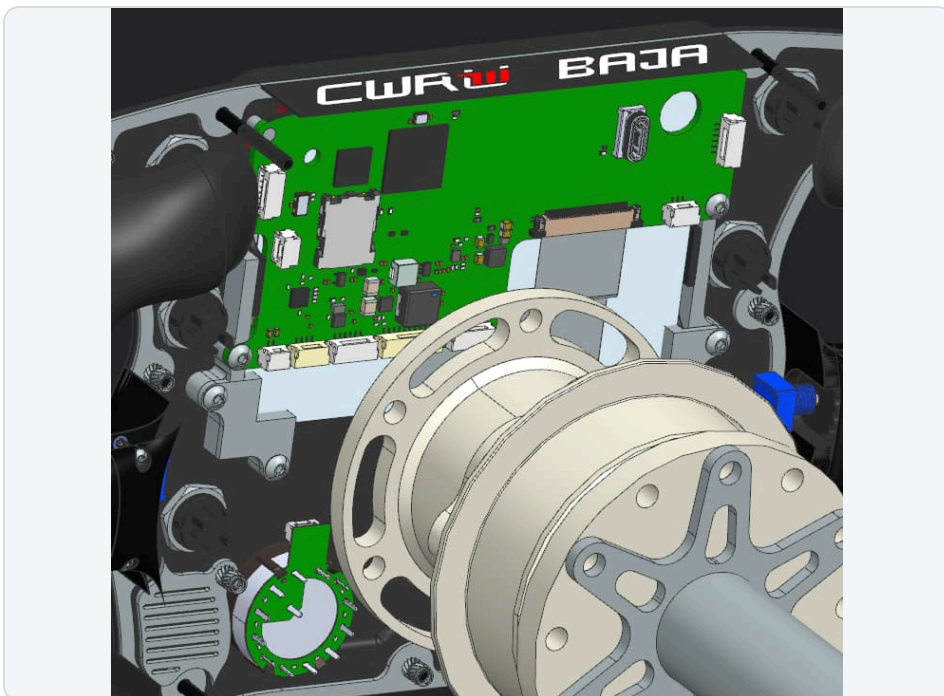
**DETAIL 8 OF 18****Rear Electronics Packaging**

- Rear CAD view with enclosure hidden showcases screen PCB, front encoder PCB packaging, and cable routing
- I even CAD modeled display cables to verify clearance before manufacturing

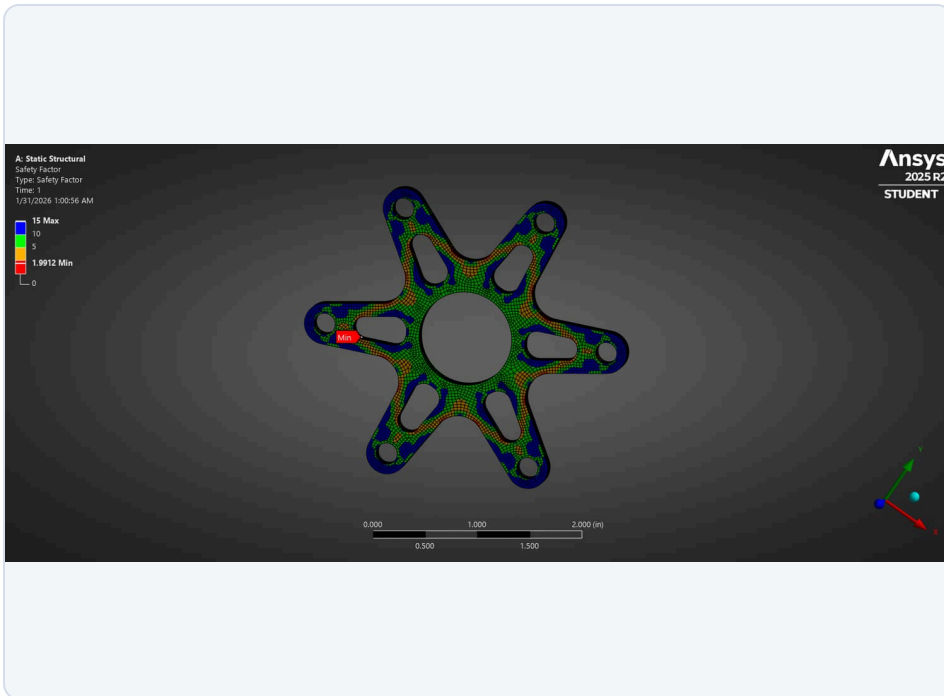
**DETAIL 9 OF 18****Steering Column Mount FEA**

- ANSYS validation of the updated steering mount was performed using a 160 lb steering force moment
- The design was waterjet machined, and it achieved approximately 2 factor of safety while maintaining the same weight as SR25's mount
- This new design supports the larger 70mm quick release mounting pattern

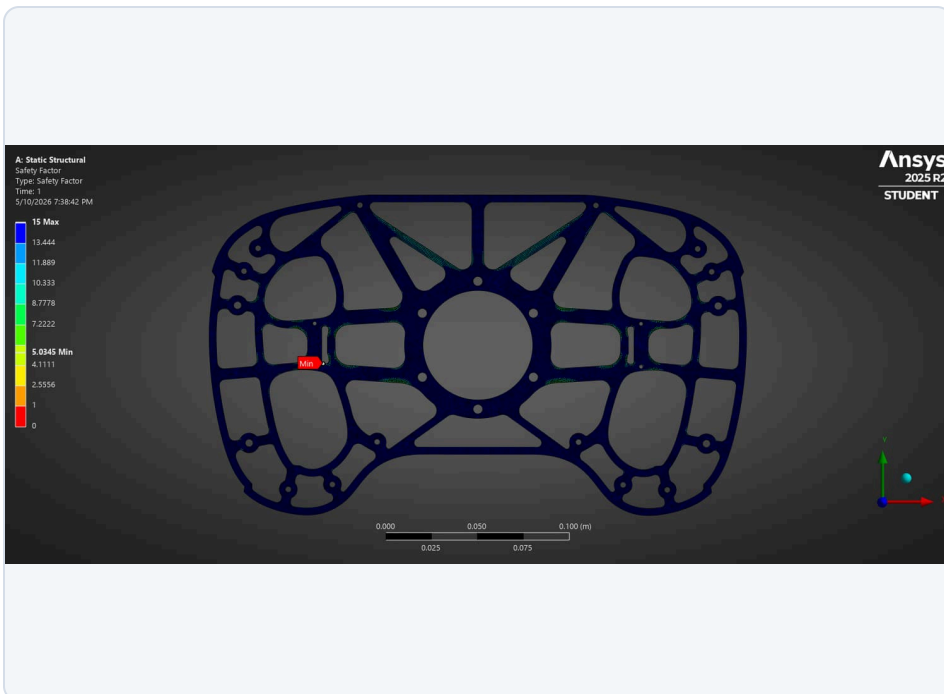
**DETAIL 10 OF 18****Wheel Frame FEA**

- The wheel frame was validated in ANSYS around a 5 factor of safety using a 160 lb applied steering force moment
- I optimized weight cutouts and removed unnecessary webbing while maintaining weight/strength targets
- The final structure weighed approximately 0.51 lb (same as SR25) despite increased wheel dimensions (0.5" wider than SR25)

**DETAIL 11 OF 18****Finished Wheel Frames**

- The waterjet manufactured wheel frames were finished with black powder coating

**DETAIL 12 OF 18****Prototype Test Fitting**

- Test fits of 3D printed components and carbon fiber front panel assembly were performed
- Driver feedback during testing validated ergonomic improvements

**DETAIL 13 OF 18****Rear Prototype Assembly**

- Rear view of physical prototype showcasing paddle mounts, quick release system, and custom handles

**DETAIL 14 OF 18****Carbon Fiber Panel Bonding**

- I bonded front panel inserts directly onto the carbon fiber plate
- The polycarbonate screen cover was also bonded directly into the assembly



VIEW VIDEO ON WEBSITE

<https://laith-wattar.com/projects.html>

DETAIL 15 OF 18

Pong Working on the Wheel 🤖

- The systems team even got pong to work on the wheel!
- Doom is up next 🐼



DETAIL 16 OF 18

Competition Vehicle Integration

- Final SR26 wheel installed on the competition vehicle with telemetry display and shock indicators functioning

**DETAIL 17 OF 18**

Oregon Competition Durability Test

- Wheel after Baja Oregon 2026 covered in mud and debris following competition use
- Safe to say we need screen tearoffs lol
- Despite severe conditions, the wheel continued functioning reliably
- Next slide showcases teardown results validating waterproofing improvements

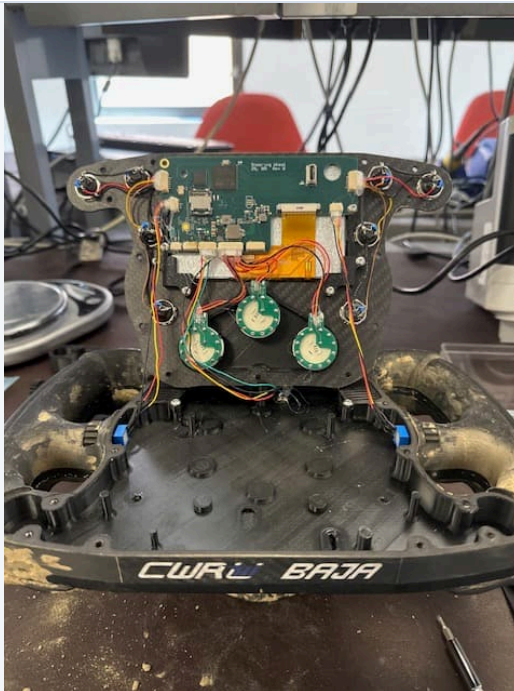
**DETAIL 18 OF 18**

Waterproofing Validation

- Post-event teardown showed no signs of mud or water ingress
- I widened gasket seating surfaces compared to SR25, and I switched to custom laser-cut EPDM foam gaskets for improved sealing
- Packaging of PCBs, buttons, and encoder systems remained fully protected!



MAIN PROJECT CARD

SR25 Steering Wheel

First-generation BAJA steering wheel featuring a 4.3" display, 6 push buttons, and 3 rotary knobs.

**DETAIL 1 OF 9**

Completed SR25 Steering Wheel

- I designed the SR25 steering wheel in Siemens NX, and manufactured the components using waterjet and 3D printing processes
- Features include a custom STM32 PCB, 6 Otto P9 push buttons, 21 LEDs, 2 thumb potentiometers, 3 rotary encoders, and a display showing RPM, speed, shock data, vehicle telemetry, etc.
- I also had to learn advanced CAD surfacing methods to create the complex rear grip geometry
- I designed the custom grips around 3D hand scans of our drivers and used experience from my Red Bull F1 replica wheel project as inspiration
- This was the first steering wheel in team history to feature an integrated display system

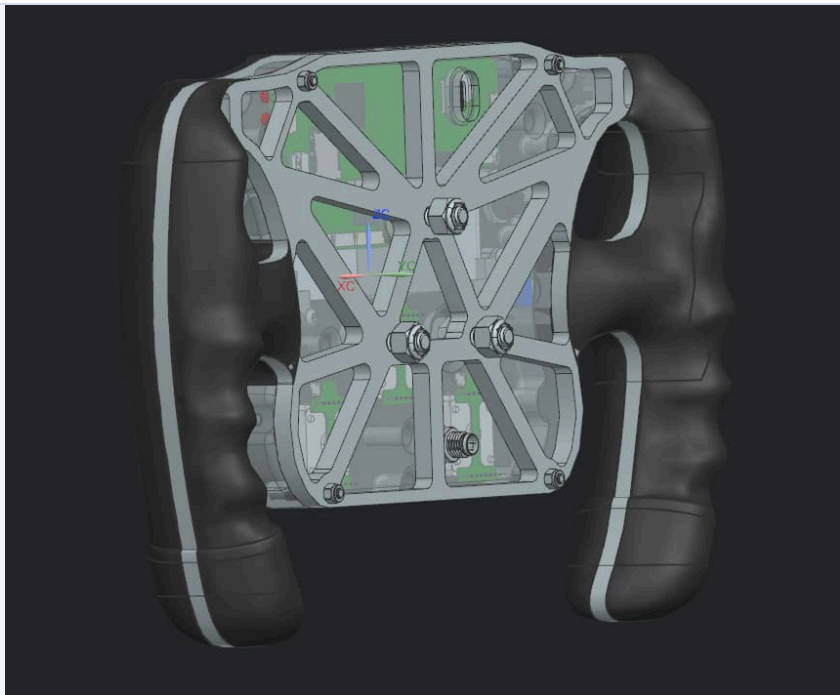
**DETAIL 2 OF 9**

Rear CAD View and Handle Grooves

- Transparent rear CAD view showcasing internal PCB and packaging layout
- This view also showcases the grooved grip geometry. This custom grip reduced driver fatigue during the 4 hour BAJA endurance races.

**DETAIL 3 OF 9****Front View of CAD Model**

- Front CAD showing updated "knurled" grip geometry and front panel packaging layout
- CAD development focused heavily on ergonomics, manufacturability, and serviceability

**DETAIL 4 OF 9****Push-To-Talk Paddle System**

- Rear paddle system uses neodymium magnets and micro-switches to provide tactile driver feedback
- I selected paddles over buttons to improve usability while preserving front panel controls for shock macros
- We also wanted to avoid routing the mic cable through the electronics enclosure due to EMI issues in old designs

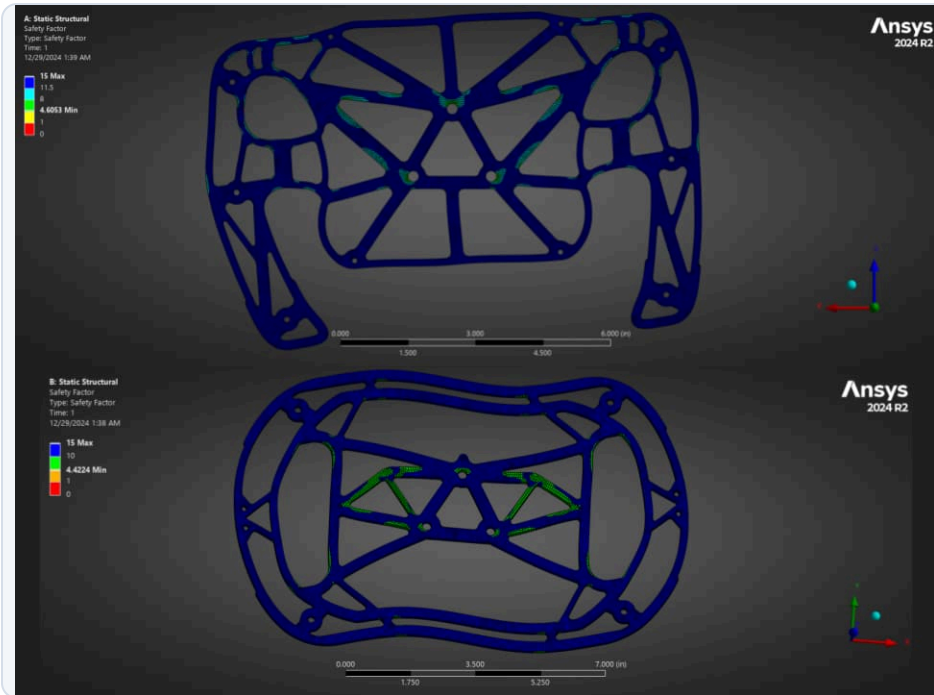
**DETAIL 5 OF 9****SR23 vs SR25 Structural Optimization**

- I performed FEA in Ansys comparing SR23 and SR25 wheel structures under a 120 ft-lb applied steering moment
- The SR25 wheel achieved similar performance while weighing 0.52 lb total (0.07 lb decrease)
- Design iterations balanced FOS against diminishing returns/complexity from additional lightweighting

**DETAIL 6 OF 9****Me sitting in SR25 trying out the wheel**

- Image shows SR25 installed inside the competition vehicle with live telemetry functioning
- Special thanks to Zach Brown for designing the display PCB, and Ben Roy for display driver integration

Zach Brown: <https://www.linkedin.com/in/zbrown23/>

Ben Roy: <https://www.linkedin.com/in/benmroy603/>

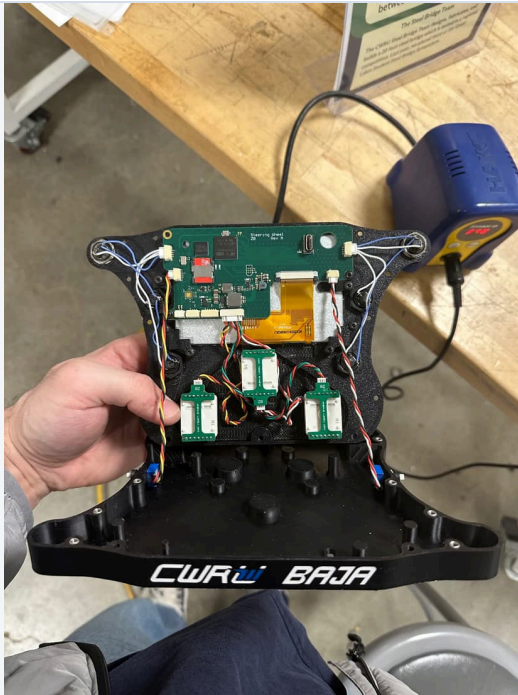
**DETAIL 7 OF 9****Electronics Packaging Constraints**

- I packaged all internal electronics within approximately 0.5 inches of enclosure depth
- Front mounting architecture prioritized easy serviceability, but severely limited the amount of space I had to work with

**DETAIL 8 OF 9****Rear Paddle Assembly**

- Paddle mounting system during assembly and enclosure integration
- Mechanical layout focused on durability, tactile feel, and repeatable driver operation

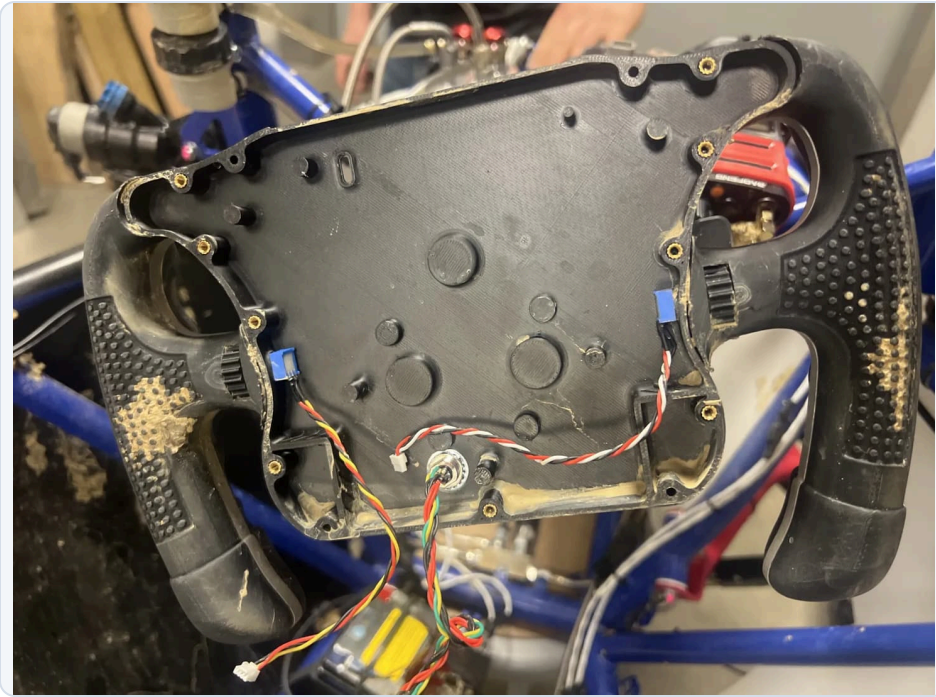
**DETAIL 9 OF 9****Waterproofing Failure Analysis**

- Competition testing revealed sealing issues with an early TPU gasket approach
- Limited gasket seating width and material stiffness reduced waterproofing effectiveness
- Lessons learned directly influenced sealing improvements in the second-generation SR26 wheel

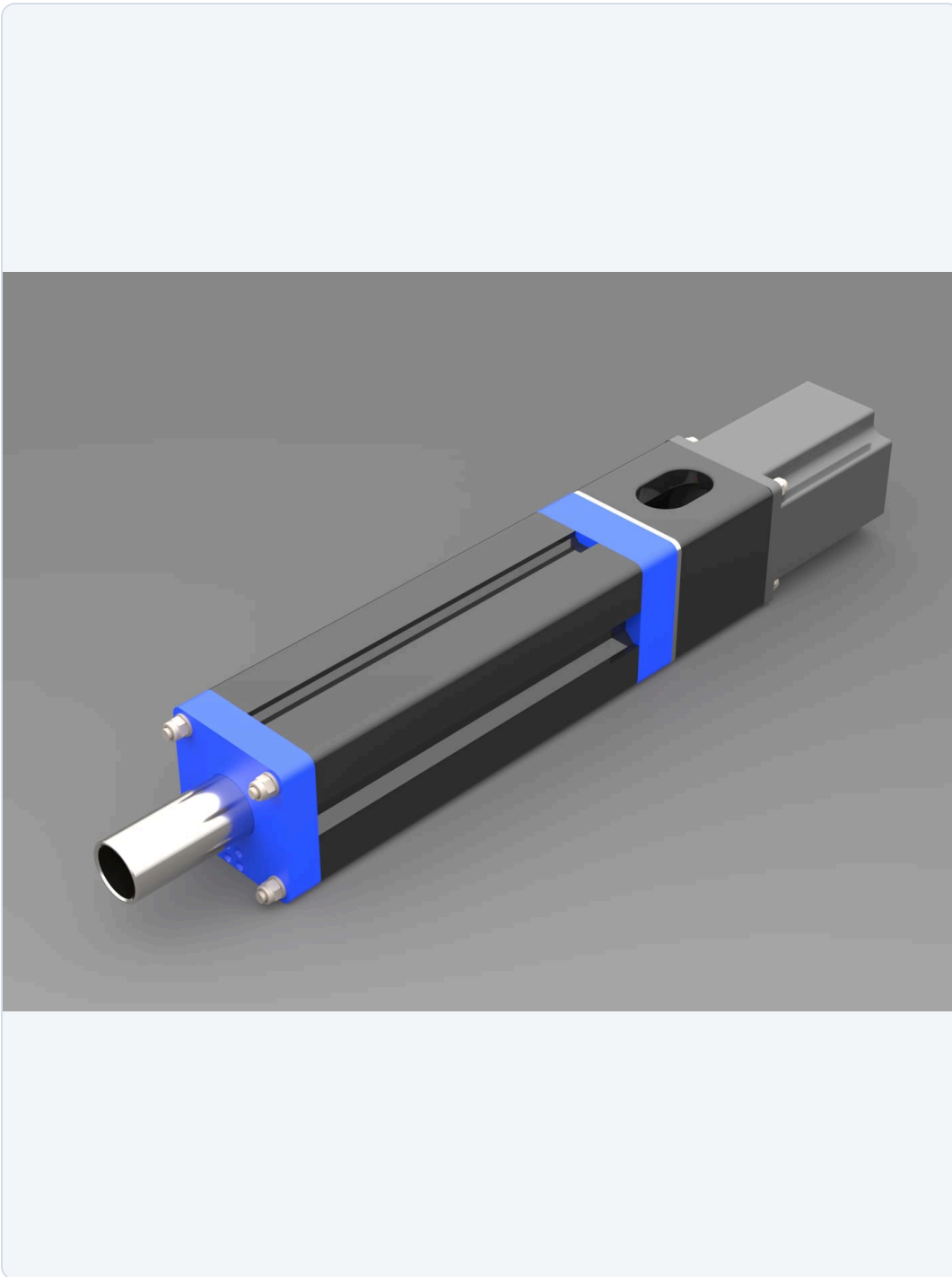
**MAIN PROJECT CARD**

Custom Linear Actuators

Designed and manufactured custom high-speed linear actuators for motion simulation based on an open-source GitHub project.

DETAIL 1 OF 8

Senior Design Intersections Poster

- Senior design project focused on developing custom linear actuators for BAJA SAE driver training
- Initial actuator architecture was based on Andrey Zhuravlev's open-source motion platform design
- Included actuator calculations, CAD development, hardware integration, and physical testing
- Open-source reference: <https://github.com/vazhure/vAzhureRacingHub>



Custom Linear Actuators for Usage in BAJA SAE Driver Training



Laith Wattar, Yousef Khalaf, and Diego Acosta-Felix, Department of Mechanical Engineering, Case Western Reserve University

Introduction

Objectives: Design a linear actuator to replicate BAJA SAE suspension travel and provide terrain feedback on the CWRU Model H frame, all while maintaining safety and affordability.

Through this, the following will be achieved:

- Determine target force, stroke length, and speed output (1.5G net acceleration, 140mm stroke, 400 mm/s speed) from market research
- Determine load requirements (~750 N per actuator)
- Connect servo motor and actuator to simulation software
- Design and build an actuator assembly and frame mounting system
- Validate performance through physical testing
- Create clear documentation of assembly and construction

Approaches:

- Use calculations to size the motor, gearbox, and ballscrew
- Design and analyze actuator structure and mounts in CAD
- Build a prototype from machined and 3D printed parts
- Wire the electronics and connect the servo driver with control software
- Bench-test force, speed, and repeatability



CWRU Motorsports SR21 Car (Model H)

Minimum Performance Metrics

Actuator Force Calculations:

Frame Mass:	23 kg	Motor Specs	
Frame Accessories:	12 kg	Rated Power (W)	750
Driver Weight:	90 kg	Voltage (V)	120
Total Weight (m):	125 kg	Rated Torque (Nm)	2.4
$F_{ma} = mg$ $= m(1.5g \text{ net upwards target} + 1g \text{ downwards gravity}) = 2.5g \text{ gross total}$	24.5 m/s ²	Rated Speed (RPM)	2500
Torque Required for 1610 Ballscrew	1.22 Nm (1.2 FOS, 1.46 Nm)	Max Torque (Nm)	7.2
Total Required Linear Force:	3062.5 Newtons	Max Speed (RPM)	3000
Force Per Actuator:	765.625 Newtons	Rated Current (A)	4.8

Ball Screw Calculations:

Ball Screw Lead	Pitch (mm/rev)	Required Actuator Torque (Nm) for accel/weight	Torque for 1.2 FOS	Torque Margin (Nm)	Linear Speed at 2500 RPM (mm/sec)
SFU1605	5	0.61	0.73	1.67	208.3
SFU1610	10	1.22	1.46	0.94	416.7

- The SFU1610 ballscrew was chosen due to the higher peak linear speed
- Even with the higher torque requirement of the 10 mm pitch ball screw, the actuator still retains a comfortable torque safety margin

Actuator Design and Assembly

- The actuator assembly consists of the following components:

Component	Specifications	Justification
Motor	750 W AC Servo, 2.4 Nm rated, 7.16 Nm peak	High torque density, far exceeds 1.46 Nm requirement
Ball Screw	SFU1610, 10 mm lead	Delivers target linear speed, standard industrial size
Coupler	Flexible Jaw coupler	Compensates for misalignment, helps absorb vibration
Housing	3D Printed PETG	Strong, cost effective, thermally resistant
Bearings	C7 Normal Contact Bearings	Handle axial and radial loads
Controller	STM32 Microcontroller	Real time processing, position control capability
Software	vAzhureRacingHub, SimHub	

- CAD renders:

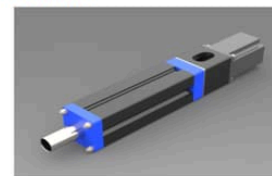

Isometric View



Cut Section View

- **STM32 Connections:**

1. PC-USB
2. Limit Switches
3. Servo Controller
4. Ground
5. Serial connection to STM32 chain



Motor/Servo Drive



STM 32 Array (1 Module)

Actuator Testing Results and Analyses

- Testing data for a 70 pound load can be seen below. The servo driver was set to jog mode, and the acceleration/speed limits were set to the maximum.

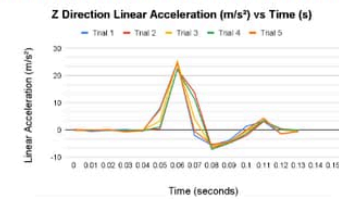

	Trial 1	Trial 2	Trial 3	Trial 4	Trial 5
Peak Acceleration (m/s ²)	24.78	20.43	25.24	22.26	24.59

- 23.9 m/s² average acceleration across all trials
- 23.9/9.81 = 2.4 g's of net vertical linear acceleration on average, **exceeding our minimum goal of ~1.5g's net acceleration**
- 23.854 m/s²* 125kg / 4 actuators = **~750 newtons of force per actuator**
- Able to exert **1800+ N** of force in severe stress test trials using 160 lb load



Load Testing (160lbs)

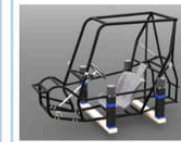

Actuators mounted to frame

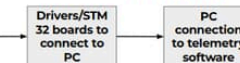

Concluding Remarks and Next Steps

- Software integration is successful, but code changes are required to unlock full linear speed functionality without using the servo driver jog mode.
- Prototype actuator has been fully designed, manufactured, and assembled.
- Frame assembly CAD is complete. Actuators will be mounted to a base instead of existing shock mounts due to issues constraining the degrees of freedom and missing suspension geometry.
- Minimum performance metrics were calculated and the physical results exceeded these requirements.
- Future tasks include completing the assembly of 3 more actuators using the Sears think[box] student project fund.

Acknowledgements

This work is sponsored by the CWRU Department of Mechanical and Aerospace Engineering. This work will be continued and expanded upon through a sponsorship provided by the Sears think[box].

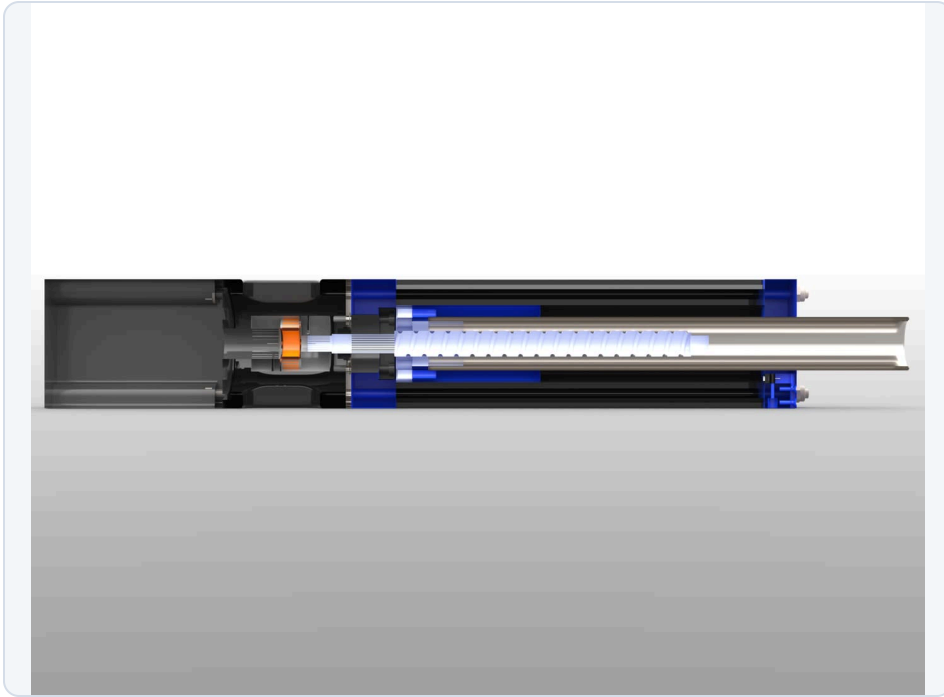

**DETAIL 2 OF 8****Actuator Cutaway Render**

- Cut-section render showing the internal actuator structure
- Includes a 750W AC servo motor, SFU1610 ballscrew, coupler, bearings, and PETG enclosure
- Designed around high-speed linear motion and compact packaging requirements

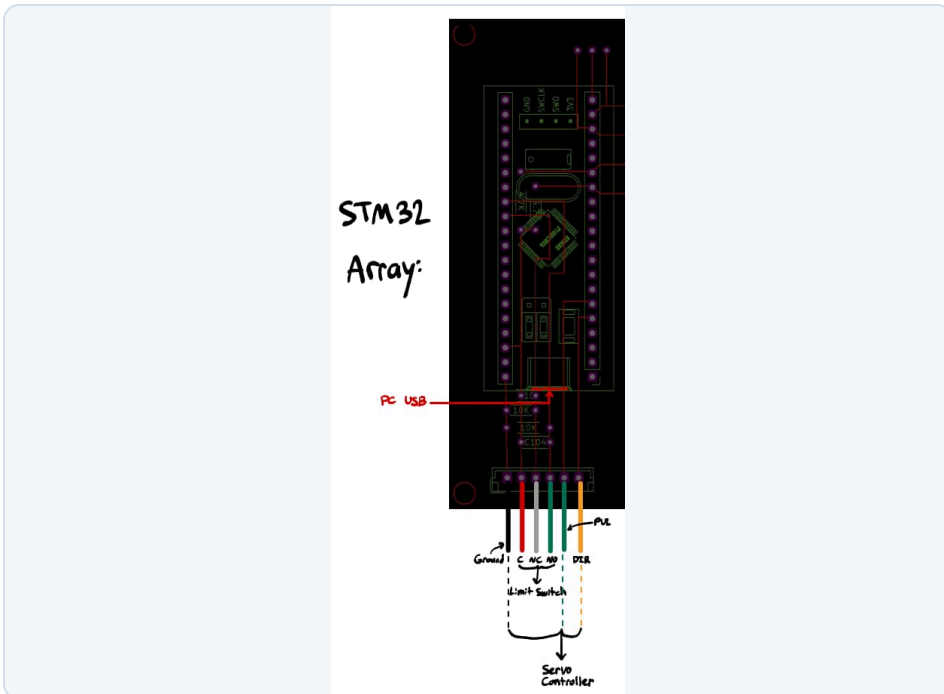
**DETAIL 3 OF 8****STM32 Controller Connections**

- Control system built around a 1 master, 4 slave STM32 microcontroller array
- Master STM32 handles PC communication while slave boards generate servo pulse outputs
- Includes USB serial communication, shared grounding, and limit switch connections
- All STM32s were mounted to a custom PCB in the electronics enclosure

**DETAIL 4 OF 8****Electronics Wiring Enclosure**

- Central enclosure containing servo drive wiring and STM32 control hardware
- Integrated a shared ground bus bar across the enclosure panels and servo drives
- Added an EMI filter to improve electrical stability and reduce noise

**DETAIL 5 OF 8****Servo Drive Integration**

- Front view of the completed servo drive and STM32 control array
- All four servo drives communicate with the simulator control system simultaneously
- Includes an audio amplifier used to drive bass shakers mounted to the rig



VIEW VIDEO ON WEBSITE

<https://laith-wattar.com/projects.html>

DETAIL 6 OF 8

Initial Actuator Testing

- Early actuator testing using the desktop telemetry control application
- Motion response was functional but initially limited in speed
- Later firmware and software optimizations significantly improved actuator performance



VIEW VIDEO ON WEBSITE

<https://laith-wattar.com/projects.html>

DETAIL 7 OF 8

160 lb Load Capacity Testing

- Physical load testing performed using approximately 160 lbs of weight
- Testing validated over 1800 N of total actuator force output
- Experimental results exceeded the original target acceleration requirements from the senior design study

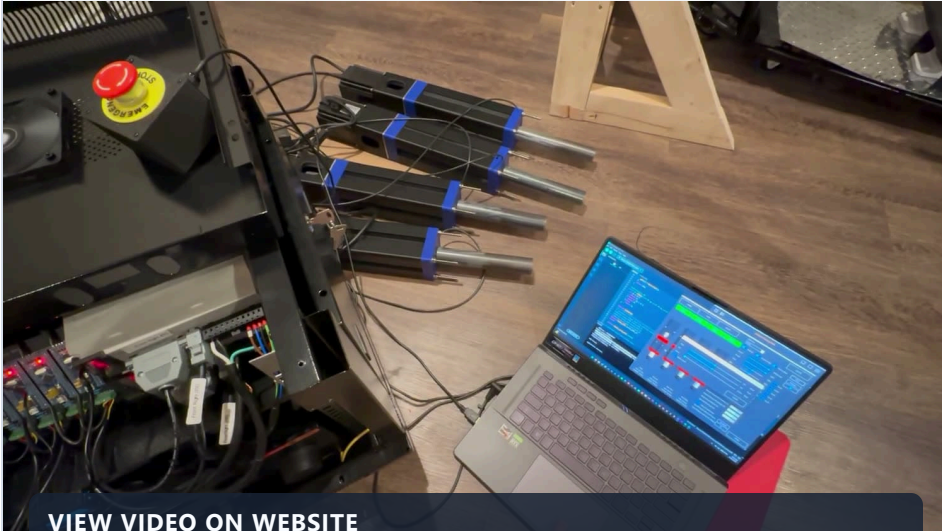

VIEW VIDEO ON WEBSITE

<https://laith-wattar.com/projects.html>

DETAIL 8 OF 8

400 mm/s Firmware Upgrade

- Demonstrates all four actuators running on updated high-speed firmware
- Activated STM32 hardware timers for faster pulse generation
- Increased maximum actuator speed from approximately 150 mm/s to 400 mm/s
- Custom firmware fork:
https://github.com/lawattar/vAzhureRacingHub/blob/main/MotionPlatform3/1dof/STM32_Code_V3.ino



MAIN PROJECT CARD

Red Bull F1 Steering Wheel Replica

Custom F1 wheel replica using models from Pokorny Engineering. This was my first steering wheel project, and served as a strong foundation for my future BAJA designs.

**DETAIL 1 OF 3****Completed Red Bull F1 Replica Wheel**

- I manufactured and assembled a Red Bull Formula 1 style steering wheel replica for my BAJA motion simulator using DIY files from Pokorny Engineering
- I produced the components on my Bambu Lab P1S and integrated the completed wheel into my simulator platform
- Features include a 4.3" VoCore display, programmable RGB LEDs, magnetic paddle shifters, rotary encoders, and authentic Formula-style controls

**DETAIL 2 OF 3****Front Assembly and Electronics Integration**

- I assembled the front controls and electronics while integrating the display, programmable lighting, switches, and rotary controls
- The design includes ergonomic grips, multiple encoder inputs, and adjustable button lighting inspired by modern Formula 1 steering systems



DETAIL 3 OF 3

Rear Structure and Paddle System

- Rear view showcasing the quick release mechanism, dual clutch paddles, magnetic shift paddles, and carbon fiber reinforced structure

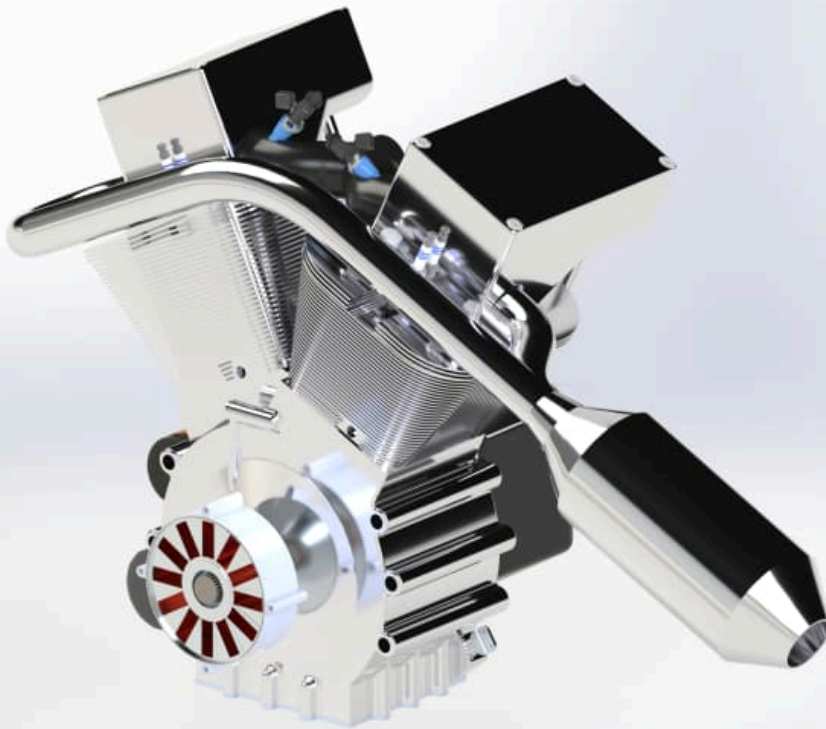

MAIN PROJECT CARD

Custom V-Twin Motorcycle Engine

Custom V-twin engine modeled from the ground up with emphasis on thermodynamic modeling, manufacturability, mechanical analysis, and market feasibility.

Go to website to download report: <https://laith-wattar.com>

**DETAIL 1 OF 9****Front Engine Render**

- 1800cc V-twin motorcycle engine designed for EMAE 360 Design and Manufacturing II (senior capstone course)
- Worked as CAD and FEA lead within a 10-person engineering team
- Designed around a longitudinal camshaft architecture inspired by the Drysdale Godzilla V-twin
- Focused on manufacturability, durability, and real-world consumer demands

**DETAIL 2 OF 9****Rear Engine Render**

- Rear view showcasing exhaust routing, intake packaging, and cylinder layout
- Integrated water cooling passages and lubrication routing in the crankcase
- Engine designed to meet CARB emissions requirements while maintaining cruiser-style performance

**DETAIL 3 OF 9****Valve and Cranktrain Motion**

- Animated render of the cranktrain, valvetrain, and longitudinal camshaft system
- Helical camshaft configuration chosen to challenge conventional V-twin packaging approaches
- Inspired by the Drysdale Godzilla V-twin engine
- Reference: <https://thekneeslider.com/drysdale-godzilla-v-twin/>

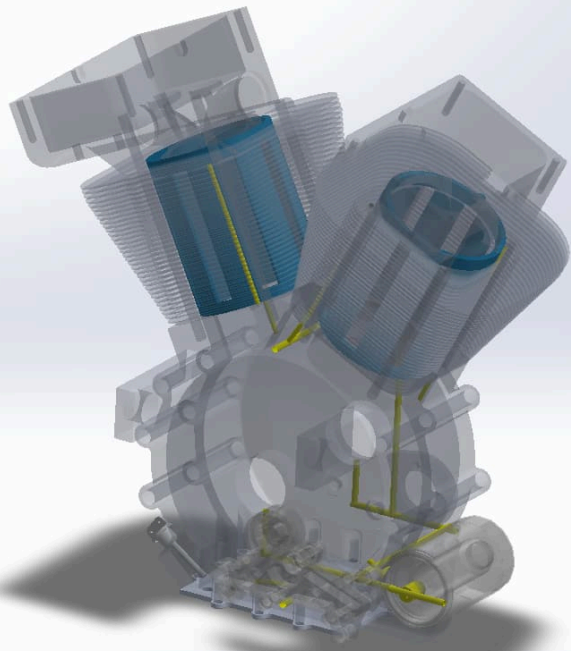
VIEW VIDEO ON WEBSITE<https://laith-wattar.com/projects.html>**DETAIL 4 OF 9****Cooling and Lubrication Paths**

- Visualization of internal coolant and oil routing throughout the engine
- Cylinder walls use water cooling passages for thermal management
- Mechanical oil pump supplies lubrication to the crankshaft journal bearings and rotating assemblies

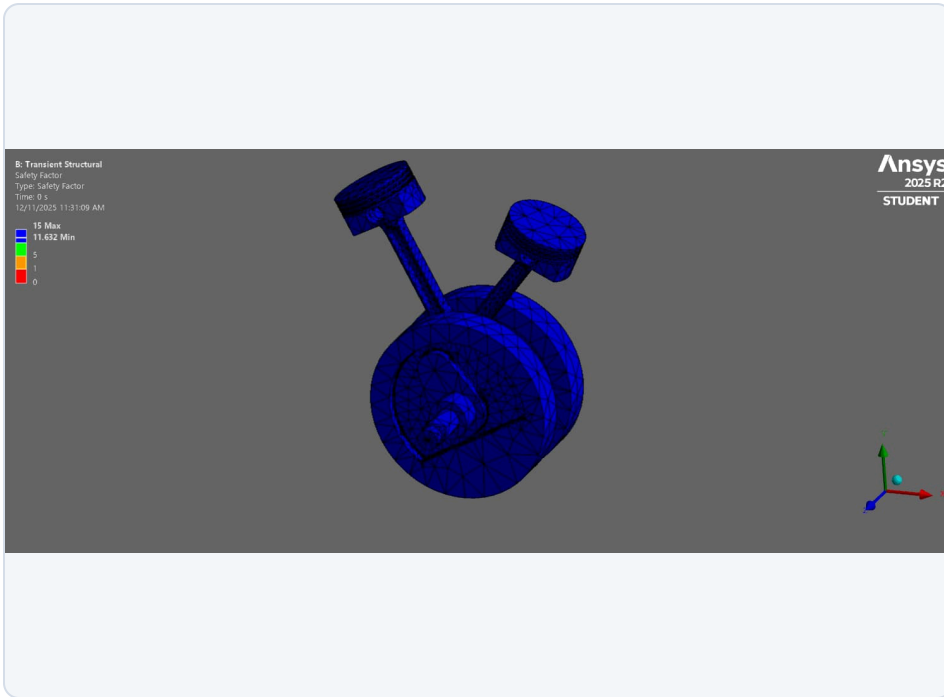

DETAIL 5 OF 9

Transient Cranktrain FEA

- Transient ANSYS simulation used to validate cranktrain loading across the engine cycle
- Compared transient FEA forces against original MATLAB dynamic force calculations
- Despite student-version node/mesh limitations, results closely matched the hand-calculated loading values
- Used to verify crankshaft, piston, and connecting rod design loads before final FEA analysis

4.7 Cranktrain Transient FEA Analysis

Given the critical design constraints established by our matlab force script **CrankTrain FEA Forces.m**, we performed a transient simulation of the crankshaft, connecting rods, and pistons to verify the accuracy of our values. To begin, we tabulated cylinder pressure as a function of time. Assuming a 720-degree engine cycle and operation at the design maximum of 6000 RPM, this equates to a step size of 0.000277 seconds per degree of rotation. We previously solved for the cylinder pressure as a function of crank angle in section 4.5.2, and a snapshot of the corresponding Excel data is shown in Table 4.4 below:

Time (sec)	Theta (deg)	Theta (rad)	Cylinder Volume $V(\theta)$	Cylinder Pressure $p(\theta)$
0	0	0	0.0001016470588	101325
0.0000277777777778	1	0.01745329252	0.0001017328011	101325
0.0000555555555556	2	0.03490658504	0.000101989986	101325
0.0000833333333333	3	0.05235987756	0.0001024184877	101325
0.0001111111111111	4	0.06981317008	0.0001030180969	101325
0.0001388888889	5	0.08726646266	0.0001037885206	101325
0.0001666666667	6	0.1047197551	0.0001047239823	101325
0.0001944444444	7	0.1221730476	0.0001058402225	101325
0.0002222222222	8	0.1396263402	0.0001071204986	101325
0.00025	9	0.1570796327	0.0001085695857	101325
0.0002777777778	10	0.1745329252	0.0001101867766	101325

Table 4.4: Snapshot of Existing Flywheel Data

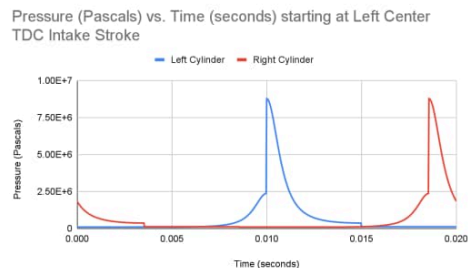

DETAIL 6 OF 9

Cylinder Pressure and Force Generation

- Calculated cylinder pressure and cranktrain loading for every degree of crank rotation
- Generated transient loading tables and pressure curves through extensive Excel and MATLAB analysis
- Used these values as inputs for the transient FEA simulations throughout the project
- Additional derivations and calculations are documented in the downloadable report

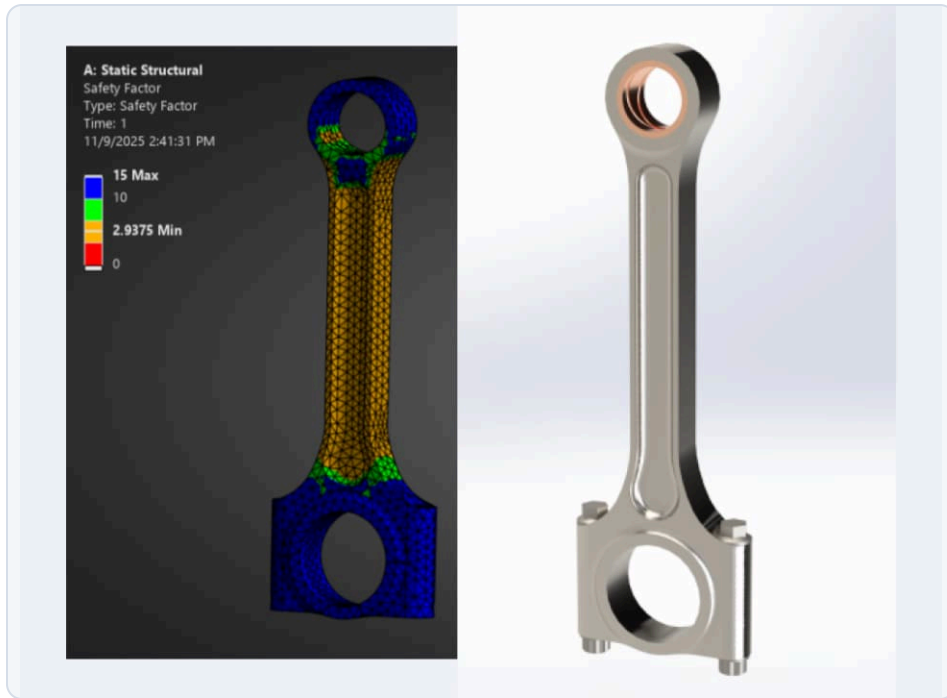
**DETAIL 7 OF 9****Connecting Rod Design and FEA**

- Designed custom connecting rod geometry and validated it through ANSYS structural analysis
- Targeted a minimum factor of safety of 3.0 to satisfy class design requirements
- Optimized geometry to reduce weight while maintaining durability under peak combustion loads
- Manufacturing and material selection details are documented in the final report

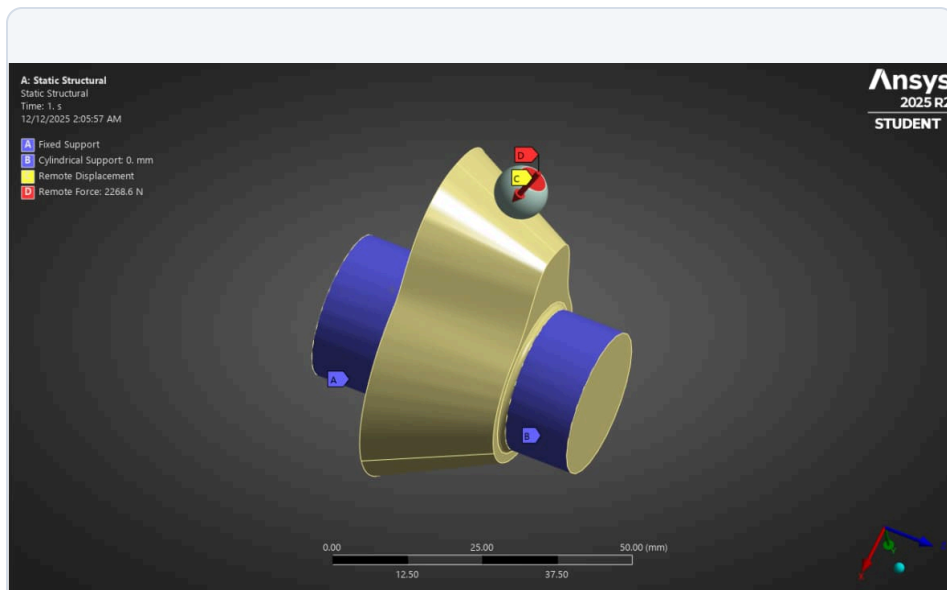

Figure 5.34: Camshaft FEA Setup

DETAIL 8 OF 9**Camshaft Contact Pressure FEA**

- Contact pressure analysis used to evaluate cam lobe durability and wear characteristics
- Spring forces were derived through valvetrain dynamics and valve spring calculations
- Results helped determine whether cast iron camshaft lobes would provide sufficient durability versus forged alternatives

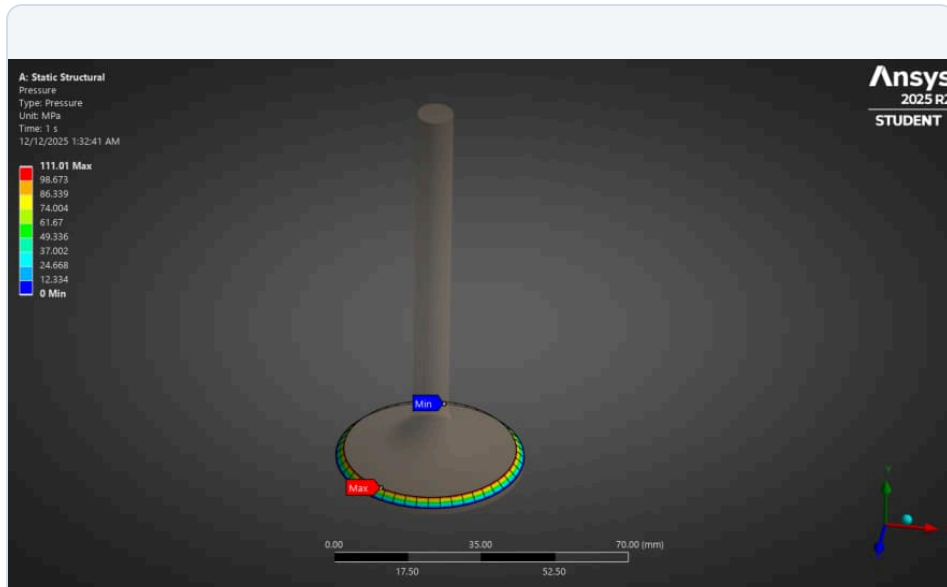

Figure 5.11: Intake Valve Contact Pressure

DETAIL 9 OF 9

Valve Contact Pressure FEA

- Contact pressure simulation performed on the intake valve and valve seat interface
- Validated that the selected valve geometry could safely withstand the required spring forces
- Used to confirm durability and fatigue performance of the valvetrain assembly

**MAIN PROJECT CARD**

Agricultural Drone Design

Heavy-lift agricultural drone concept designed around payload capacity, power systems, and long-endurance flight.



DETAIL 1 OF 2

Hexacopter CAD Render

- Served as CAD lead for overall drone architecture and assembly
- Researched motor and propeller combinations to improve flight efficiency
- Performed battery sizing calculations to optimize range and payload capacity
- Integrated structural, propulsion, and payload systems

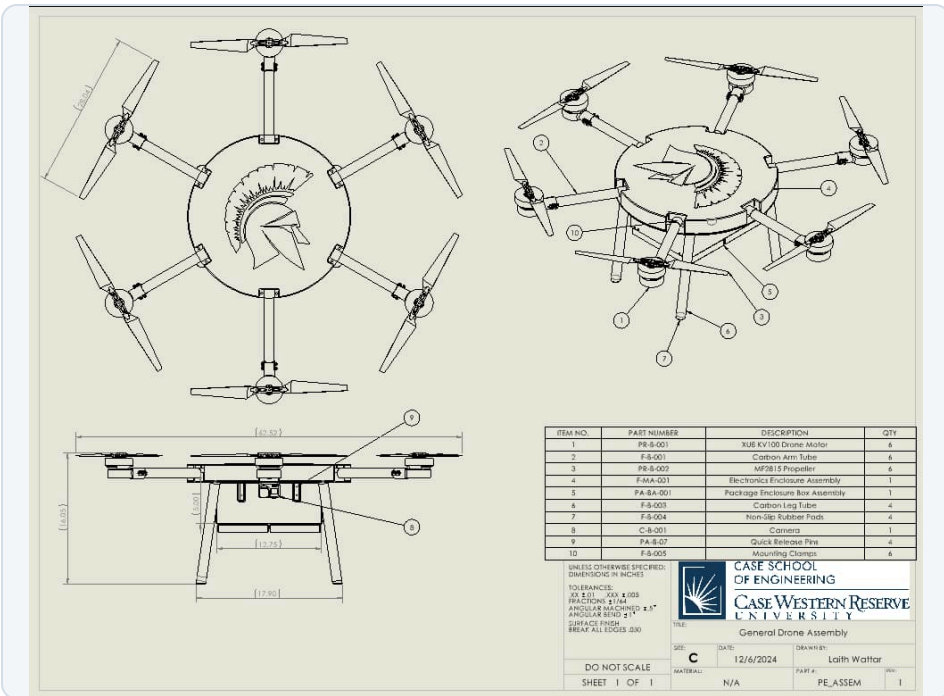

DETAIL 2 OF 2

Engineering Assembly Drawing

- Created fully detailed drone assembly drawings and layouts
- Used numbered callouts and BOM references for component identification
- Prepared technical documentation for manufacturing and team review



MAIN PROJECT CARD

CWRU Motorsports LED Sign

Custom designed and manufactured a CWRU BAJA sign to display in our team workspace in Sears think[box].



VIEW VIDEO ON WEBSITE

<https://laith-wattar.com/projects.html>

DETAIL 1 OF 2

CWRU Motorsports Addressable LED Sign Demo

- I created a custom CWRU Baja LED sign using individually addressable WS2815 LEDs and ESP32 wireless control
- I designed the LED sign using Siemens NX and 3D printed all parts on my Bambu Lab P1S
- I performed testing to optimize 3D printed diffuser thickness and minimize LED hotspot visibility (less visible in real life compared to camera)
- I integrated WLED firmware for mobile control over colors, animations, and lighting effects



DETAIL 2 OF 2

Electronics Enclosure Assembly

- The electronics enclosure houses an ESP32, toggle switch, and 12V DC power input
- I also added a 12V to 5V buck converter to power the ESP32 from the primary supply



MAIN PROJECT CARD

Geometric LED Wall Panels

My first LED project using WS2815 LEDs and an ESP32 running WLED. Lighting modes can be controlled via a mobile app.

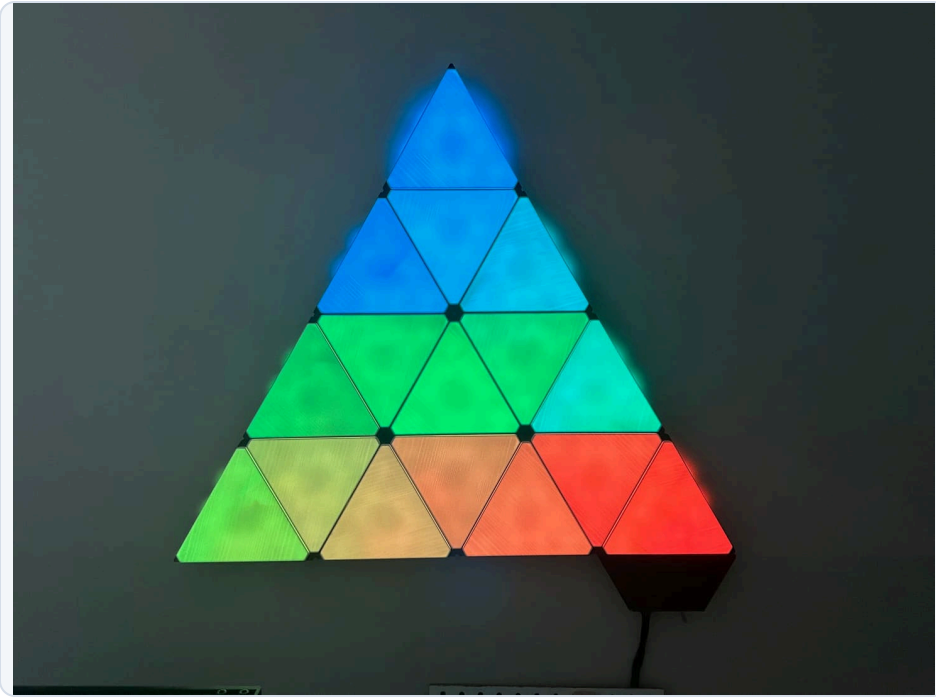
**DETAIL 1 OF 2****Geometric LED Wall Panels**

- I designed and built modular wall panels inspired by Nanoleaf lighting systems using WS2815 addressable LEDs
- I created the CAD models in SolidWorks and prepared them for 3D printing using Cura
- I manufactured the housings on my Creality CR-10 (my first 3D printer) and integrated an ESP32 running WLED for wireless control

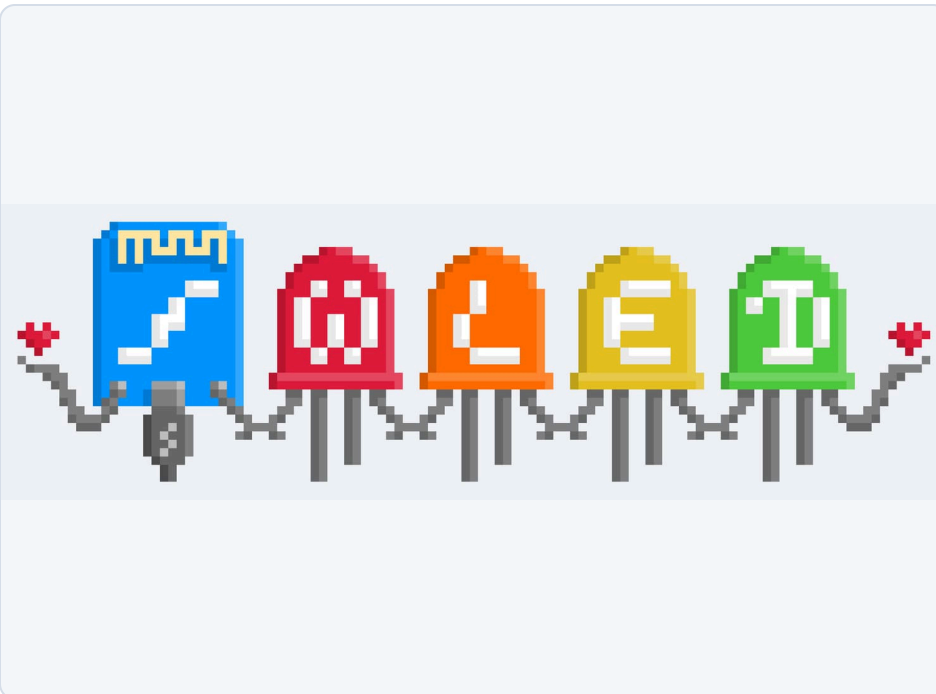
**DETAIL 2 OF 2****Power and Controls System**

- I repurposed an Xbox 360 power supply which conveniently provided both 12V and 5V rails
- The built-in voltage rails eliminated the need for an additional buck converter
- I connected the system to a smart plug for remote power control



MAIN PROJECT CARD

Greek Lithophane Lamps

Lamps designed around the Bambu Lab MH001 LED Lamp Kit that came with my P1S 3D printer.

View files online: <https://makerworld.com/en/@lawattar>



VIEW VIDEO ON WEBSITE

<https://laith-wattar.com/projects.html>

DETAIL 1 OF 6

Poseidon Lithophane Lamp

- I generated artwork and converted it into a spherical lithophane using open-source software
- I designed the lamp around the Bambu Lab MH001 LED Lamp Kit and optimized print settings for improved image clarity and light transmission
- The final design was published publicly on MakerWorld and calibrated for support efficiency, seam placement, and print quality

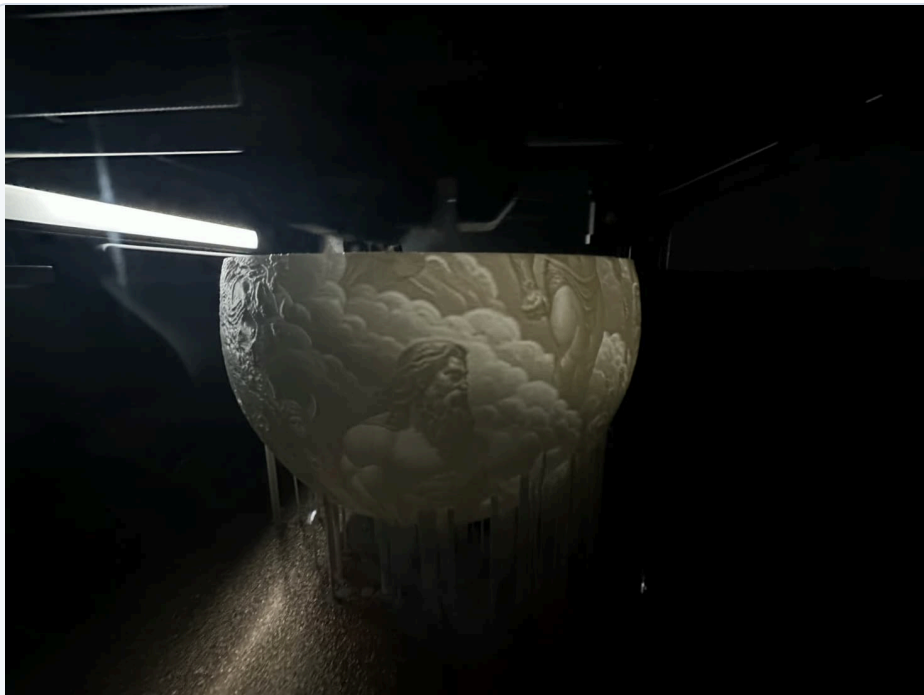

DETAIL 2 OF 6

Poseidon Lamp Print Process

- The lithophane image gradually becomes visible during printing as printer lighting passes through the changing wall thicknesses

**DETAIL 3 OF 6****Dionysus Lithophane Design**

- I created a second mythology-inspired lithophane lamp featuring Dionysus using the same spherical lithophane workflow

**DETAIL 4 OF 6****Dionysus Lamp Animation**

- Animated gif of the completed Dionysus lithophane with the led attached

VIEW VIDEO ON WEBSITE

<https://laith-wattar.com/projects.html>

**DETAIL 5 OF 6****Scene Detail Closeup**

- Close-up view showcasing the detail created through the varying wall thickness across the scene

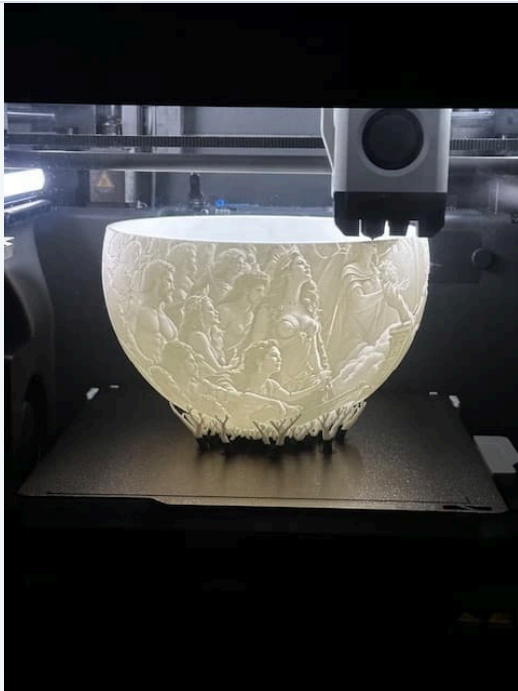
**DETAIL 6 OF 6****Dionysus Print Progress**

- Print progress view showing image formation as light passes through the lithophane

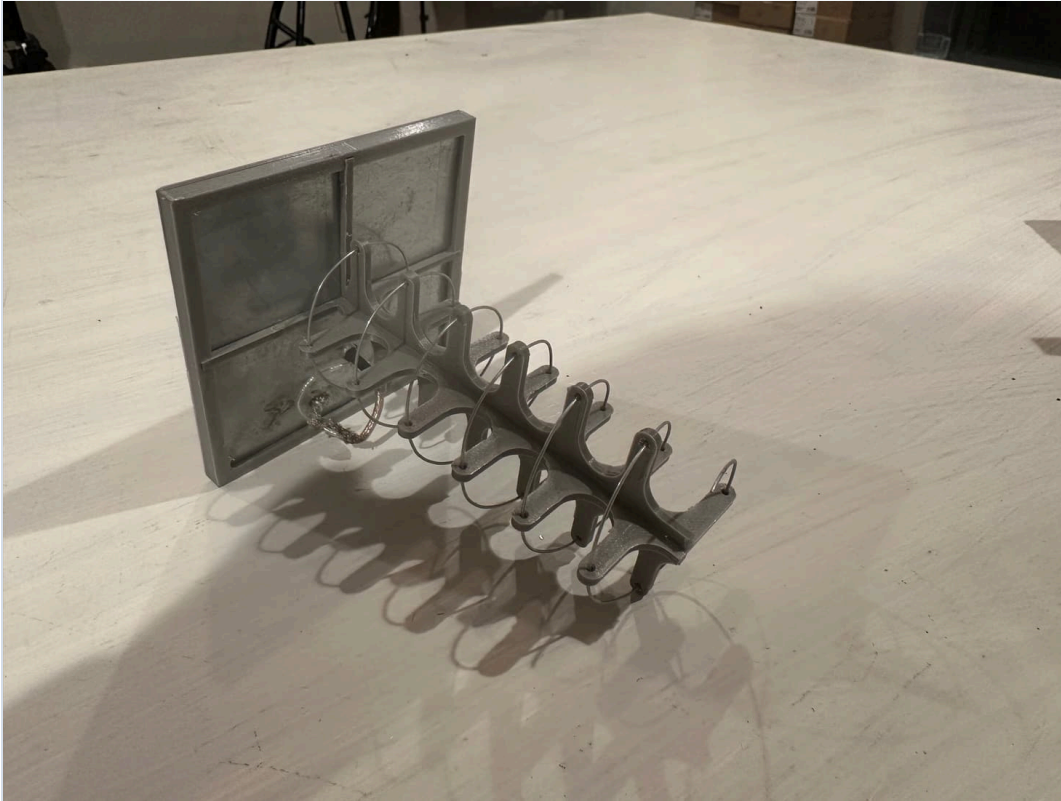
**MAIN PROJECT CARD**

Helical Antenna Design

Helical antenna calibrated for highly-directional 5 GHz WiFi.

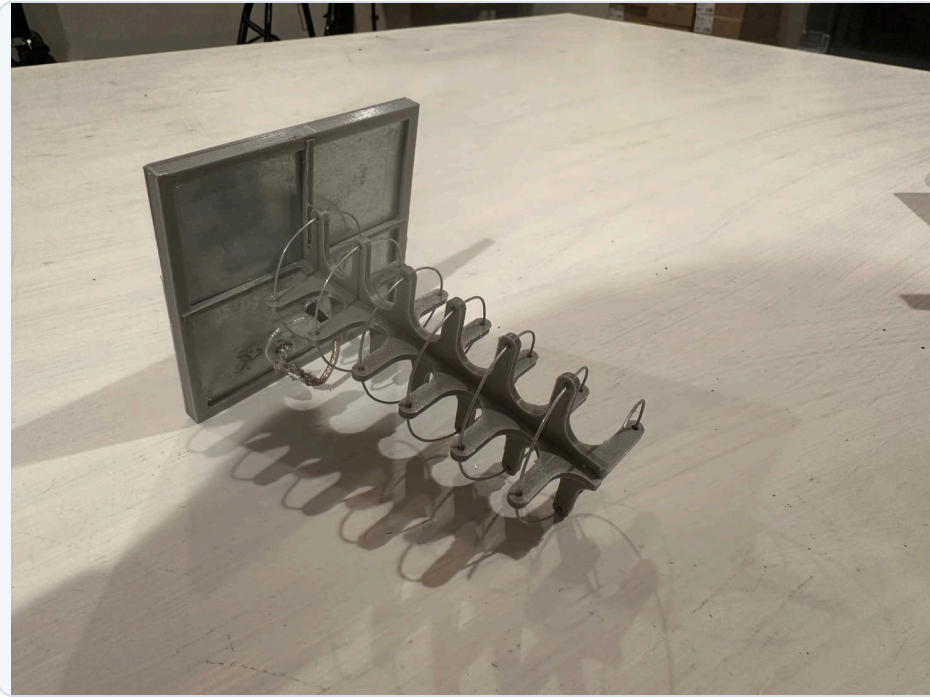
**DETAIL 1 OF 3****Final Helical Antenna Design**

- This is my final helical antenna design optimized for highly directional 5 GHz WiFi operation through winding diameter and spacing optimization
- I added a reflector to redirect radiation toward the front of the antenna and improve directional performance
- The design features an F-Type cable connection similar to those found on WiFi routers
- To create the windings, I first wrapped the wire around a mandrel to shape it and then fed it through retaining holes
- I 3D printed the antenna body on my Creality CR10

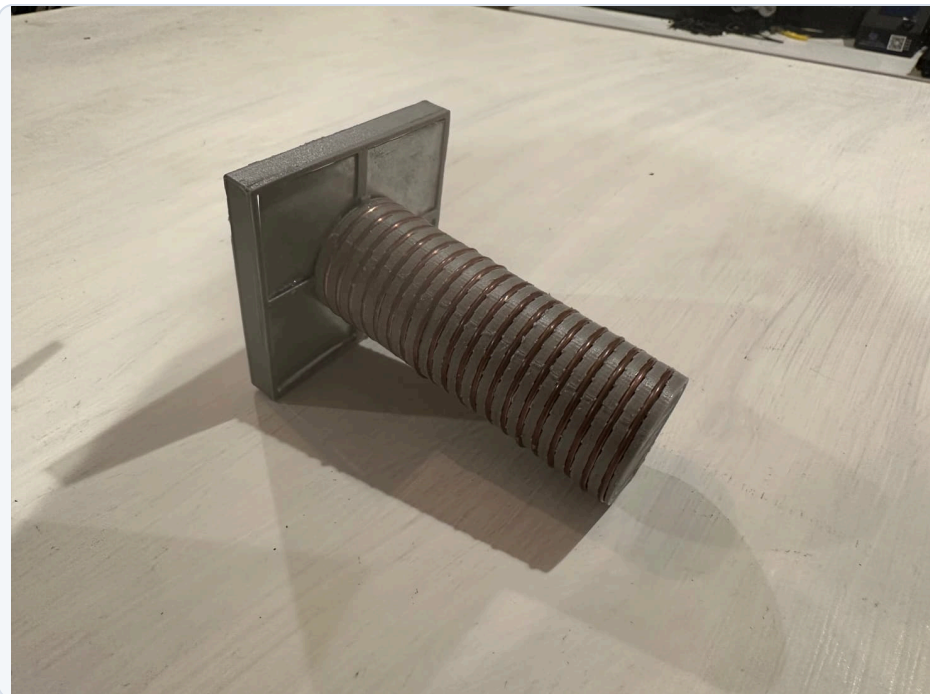
**DETAIL 2 OF 3****Initial Antenna Prototype**

- This was my initial helical antenna design before optimization
- Performance was limited due to incorrect winding spacing and diameter calculations
- The original design also used heavy solid copper wire, which added excessive weight and bent the rear F-Type connection

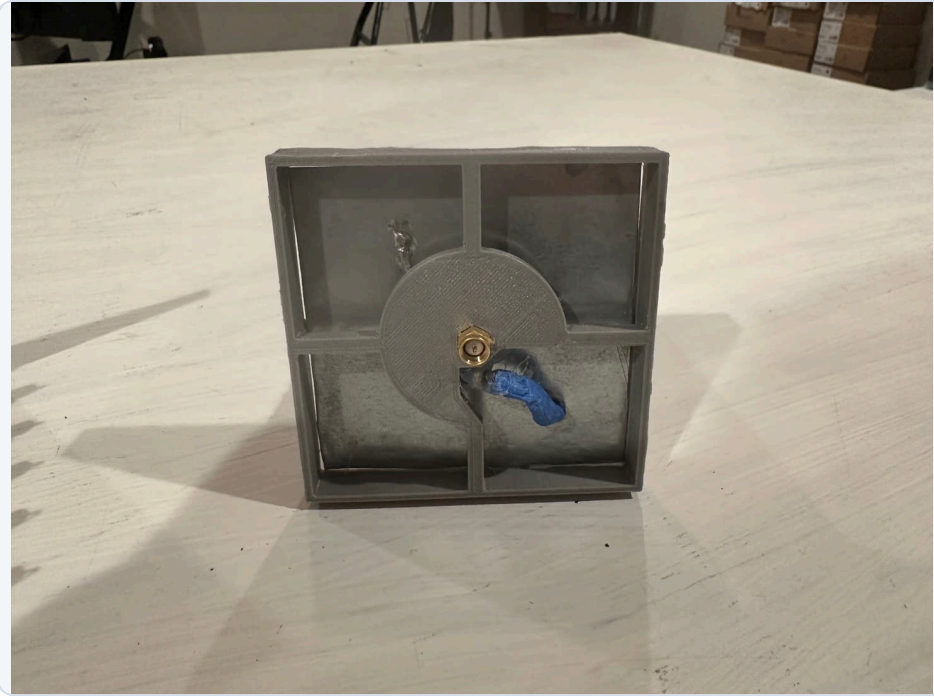

DETAIL 3 OF 3

Rear Connector

- Rear view showcasing the antenna wire passing through the reflector to the F-Type connector

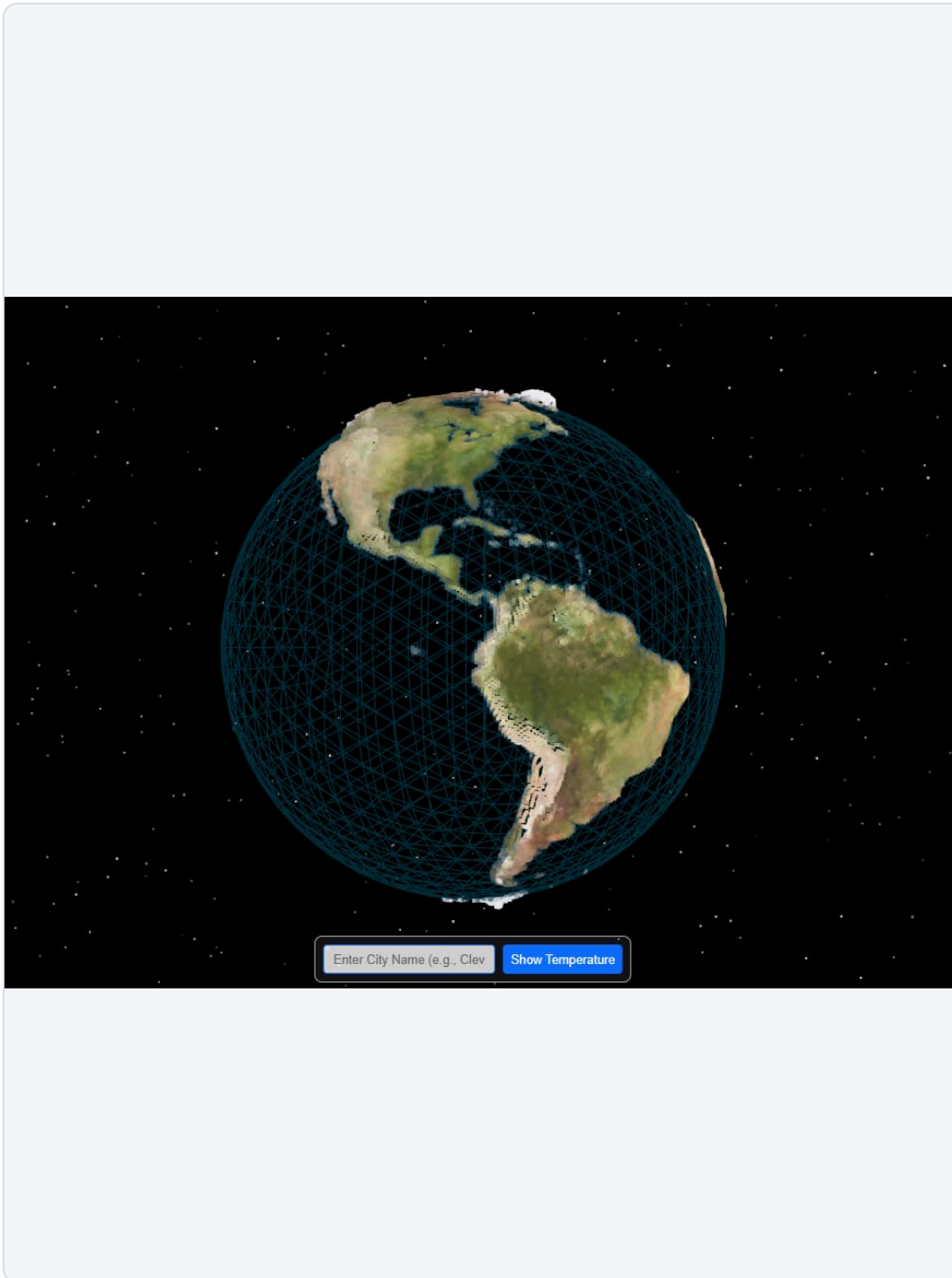

MAIN PROJECT CARD

Three.js Global Temperature UI

Interactive Three.js globe with controllable elevation parameters that pinpoints temperature and location based on user input.

VIEW VIDEO ON WEBSITE

<https://laith-wattar.com/projects.html>

DETAIL 1 OF 1

Three.js Global Temperature UI

- I designed this using HTML, CSS, and JavaScript for a web design technical elective course
- The interface uses an API to fetch weather data for a user-input location and display it on an interactive open source Three.js globe
- I added custom controls for the Three.js rendering, allowing users to adjust Earth color maps and elevation map visualization
- Try it out by clicking on the interactive embedded demo above!

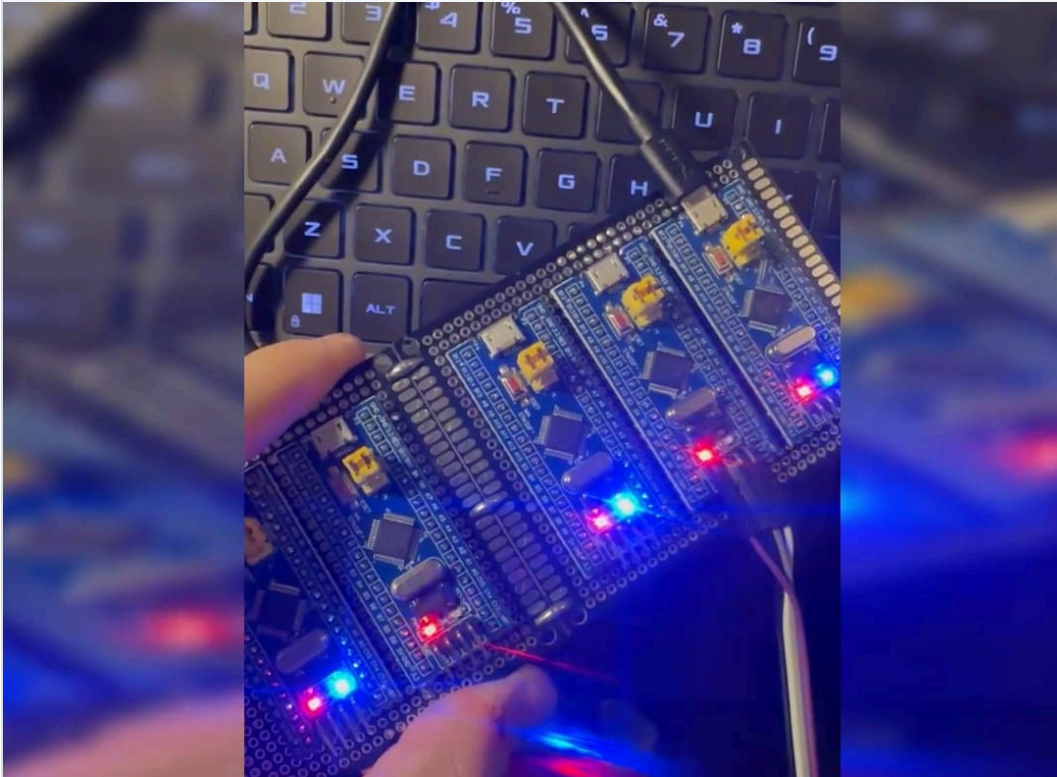

MAIN PROJECT CARD

STM32 Linear Actuator Controller

Custom STM32 array and electronics enclosure used to control my BAJA simulator linear actuators. This was based upon open source code that I improved using hardware timers.

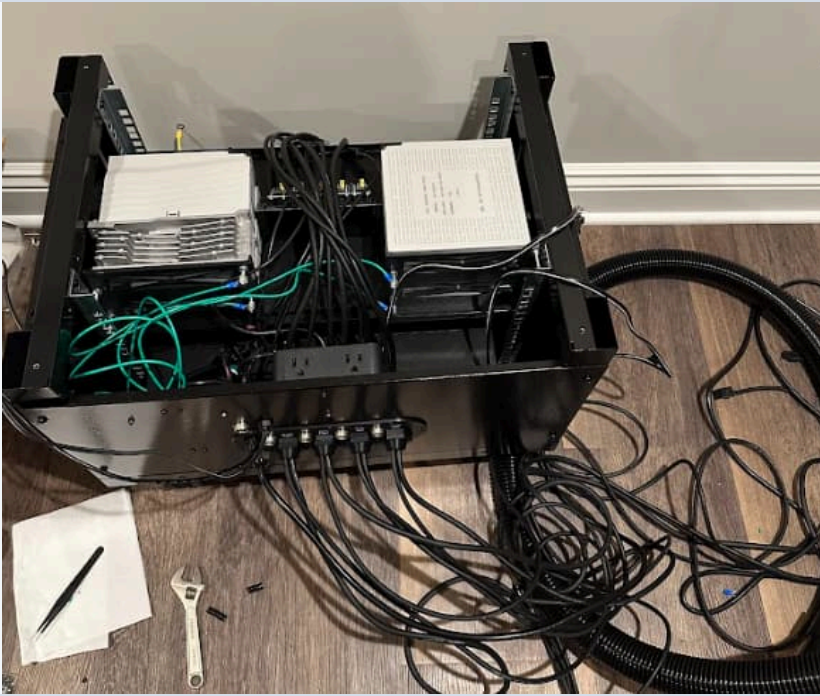
**DETAIL 3 OF 3****System Wiring and EMI Management**

- This image showcases the true extent of the wiring required for the system
- I grounded all servo controllers and enclosure panels using a shared grounding point with a dedicated bus bar
- An EMI filter was also added to minimize electrical noise and improve overall system reliability

**MAIN PROJECT CARD**

pygame Pacman

Custom version of Pacman that I coded in python/pygame during high school.

**DETAIL 1 OF 1**

Python Pacman Recreation

- I recreated Pacman in Python during high school as an early programming project
- I developed the game using PyGame while learning object-oriented programming and game development concepts
- The project helped build foundational programming experience that later expanded into larger software and embedded systems projects



MAIN PROJECT CARD

Lincoln Electric

Tool Design and Plant Engineering Intern

**DETAIL 1 OF 1****Lincoln Electric Tool Design and Plant Engineering Internship**

- I completed 200+ CAD parts across 15 projects ranging from coolant pump fixtures to electronics machine enclosures
- I collaborated with the tool room and gained hands-on exposure to CMM, Wire EDM, plasma cutting, lathes, and milling processes
- I supported manufacturing and plant engineering projects at Lincoln Electric's Euclid, Ohio facility



MAIN PROJECT CARD

ScribeAmerica

MetroHealth Emergency Room Medical Scribe

**DETAIL 1 OF 1****MetroHealth Emergency Department Medical Scribe**

- I completed 20–30 medical charts per shift while supporting emergency room physicians
- I recorded chart information and lab interpretations using Epic medical software
- I worked under HIPAA standards and patient privacy requirements in a fast-paced emergency department environment



ROCKY RIVER
R E C R E A T I O N

MAIN PROJECT CARD

Life Guard

Rocky River Recreation Center Life Guard



ROCKY RIVER
R E C R E A T I O N

DETAIL 1 OF 1

Civic Center Lifeguard

- I monitored pool areas and helped maintain a safe environment for up to 100 patrons at a time
- I assisted with deck operations, rule enforcement, and medical response situations
- I earned Red Cross CPR certification and supported daily aquatic facility operations



ROCKY RIVER
R E C R E A T I O N

MAIN PROJECT CARD

Life Guard Supervisor

Supervised life guards and maintained water chemical levels.



ROCKY RIVER
R E C R E A T I O N

DETAIL 1 OF 1**Civic Center Supervisor**

- I supervised a staff of 40+ lifeguards while coordinating rotations and daily operations
- I monitored water chemistry parameters including pH, temperature, and alkalinity
- I managed patron concerns and helped maintain a safe and organized recreational environment

**MAIN PROJECT CARD**

Computer Building

Planned and built 8 computers for family members and friends.



VIEW VIDEO ON WEBSITE

<https://laith-wattar.com/projects.html>

DETAIL 1 OF 3

High-End College Workstation Build

- Built for a friend during college as a high-performance gaming and workstation PC
- Features an Intel Core i9 processor and an ASUS RTX 4080 GPU
- Integrated a 360mm AIO cooler and multiple Lian Li infinity mirror fans



DETAIL 2 OF 3

White-Themed RGB Build

- Custom white-themed PC I built for a friend during high school
- Features an Intel Core i7 processor and Gigabyte RTX 3070 Ti graphics card
- Integrated synchronized controllable RGB lighting throughout the entire system

**DETAIL 3 OF 3****Humble Beginnings - My First Budget PC Build**

- Built in 10th grade on an approximately \$250 total budget
- Used an Intel Xeon X5675 with an X58/LGA1366 motherboard sourced from AliExpress
- Originally assembled inside a cardboard box due to having a limited budget



MAIN PROJECT CARD

Arabic Art and Calligraphies

Designed and manufactured Arabic calligraphies, graduation plaques, and keychains.

**DETAIL 1 OF 7****MSA Graduation Calligraphy**

- Created for a graduating MSA executive board member
- Designed in Siemens NX and produced on a Bambu Lab P1S
- Combined layered typography with decorative border detailing
- Established workflow for future multicolor calligraphy projects

**DETAIL 2 OF 7****Custom Drawn Calligraphy #2**

- Drew and refined the Arabic lettering manually instead of using an existing design
- Modeled and prepared geometry in Siemens NX
- Manufactured using FDM printing



DETAIL 3 OF 7

Calligraphy #3

- Created for a fellow community member
- Modeled and prepared geometry in Siemens NX
- Manufactured using FDM printing



DETAIL 4 OF 7

Custom Graduation Plaques

- Designed plaque graphics in Canva before importing into NX
- Manufactured in multicolor using a Bambu Lab P1S
- Produced multiple personalized nameplate variations
- Optimized workflow for repeatable small-batch production

**DETAIL 5 OF 7****Plaque Detail Closeup**

- Showcases the layered text and multicolor print
- Tuned print settings for improved edge quality and readability
- Demonstrates consistency across batch production

**DETAIL 6 OF 7****Competition Bookmark Set**

- Designed custom event graphics and Arabic calligraphy in NX
- Produced using multicolor FDM
- Manufactured multiple copies for community distribution

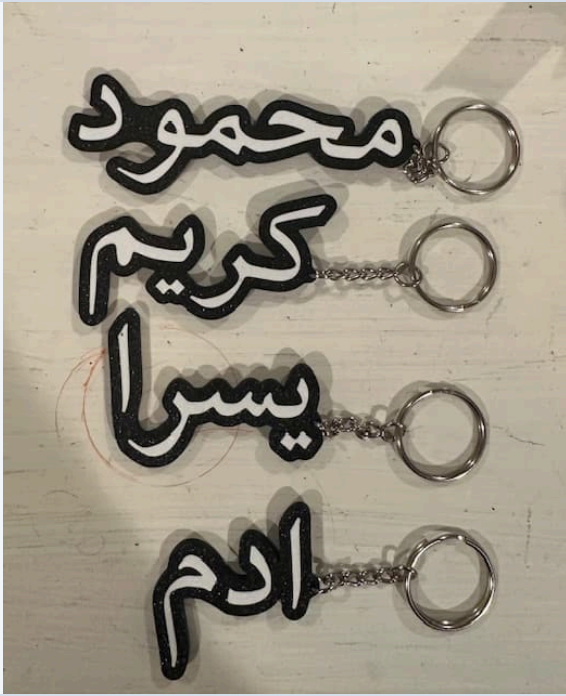
**DETAIL 7 OF 7****Arabic Name Keychains**

- Created custom Arabic name keychains for individual requests
- Manufactured using AMS multicolor printing on my P1S
- Refined text legibility for small-format details
- Produced repeatable personalized designs with minimal post-processing



MAIN PROJECT CARD

Powerlifting

I am passionate about the gym and have helped set up and run numerous powerlifting events around Cleveland and CWRU.

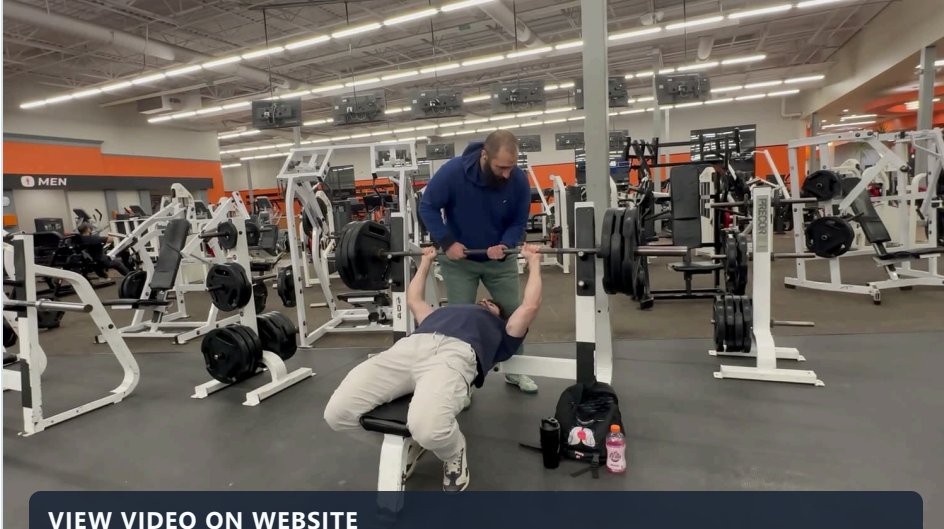

VIEW VIDEO ON WEBSITE

<https://laith-wattar.com/projects.html>

DETAIL 1 OF 1

315 lb Paused Bench Press

- 315 lb paused bench press at 198 lb bodyweight

**MAIN PROJECT CARD**

Rugby

Competed on the CWRU Rugby team throughout college.



VIEW VIDEO ON WEBSITE

<https://laith-wattar.com/projects.html>

DETAIL 1 OF 3

Match Highlight vs John Carroll

- 360 jersey tackle during a match against John Carroll University



DETAIL 2 OF 3

2024–2025 Team Season

- Team photo from the 2024–2025 CWRU Rugby season



DETAIL 3 OF 3

In-Game Defensive Play

- Defensive tackle during my first season on the team



CWRU
LIFT

MAIN PROJECT CARD

CWRU Lift

Held an executive position every year during college, including social media and design roles.

**DETAIL 1 OF 4****CWRU Lift Branding and Club Identity**

- I helped build and grow CWRU Lift, a student powerlifting organization at Case Western Reserve University
- I created club graphics, branding assets, and promotional materials for events and social media
- We focused on building an inclusive lifting community centered around strength training, competition preparation, and fitness education

**DETAIL 2 OF 4****Club Event Promotion and Graphic Design**

- These are some promotional graphics I designed for club competitions, mock meets, and social events
- I created marketing material including Lift or Treat, collegiate mock competitions, and Arnold Sports Festival recruiting campaigns

**DETAIL 3 OF 4**

Club Community and Growth

- During my time on exec, we organized club activities and supported student participation in powerlifting and strength sports
- We built a welcoming environment for 200+ lifters ranging from beginners to experienced competitors
- Some of our members have even gone on to compete at the national level!

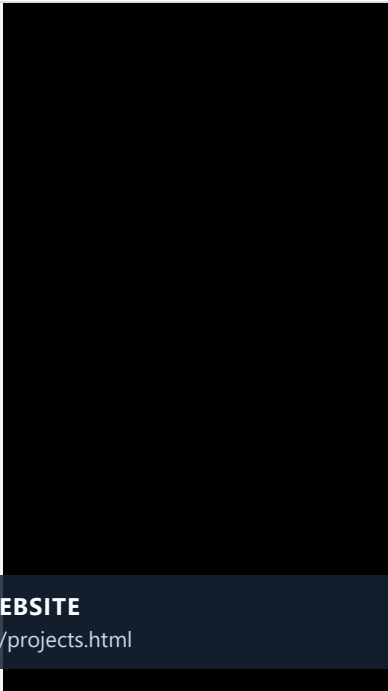
**DETAIL 4 OF 4**

Competition Highlight Reel

- This is a highlight reel I edited that showcases one of CWRU Lift's full mock powerlifting competitions
- As social chair, I captured the meet atmosphere, athlete performances, and community engagement throughout the event
- I produced instagram social media content to promote the organization and document club activities

VIEW VIDEO ON WEBSITE

<https://laith-wattar.com/projects.html>

**MAIN PROJECT CARD****CWRU MSA**

Helped unite Muslims across campus by planning and running club events and fundraisers.

**DETAIL 1 OF 3****Muslim Student Association**

- I served as Social Chair for CWRU MSA and helped plan events for a community of 400+ members
- I collaborated with nearby universities on fundraisers, social events, and community initiatives
- I helped strengthen student connections through programming focused on community, faith, and campus engagement

**DETAIL 2 OF 3****MSA Soccer Event**

- I helped organize recreational events such as soccer games to strengthen community engagement outside of campus programming

**DETAIL 3 OF 3****Halaqah and Religious Discussion**

- Regular halaqah gatherings provided opportunities for religious discussion, reflection, and community learning

**MAIN PROJECT CARD**

Case Surgical Society

Surgical-interest club involvement with events, hands-on sessions, and student collaboration.

**DETAIL 1 OF 1****Surgical Skills and Case Review**

- Attended weekly surgical case discussions and procedure reviews
- Practiced suturing and knot-tying techniques on silicone training pads
- Participated in human cadaver dissection sessions with the CWRU medical school

**MAIN PROJECT CARD**

Center for Civic Engagement & Learning

Volunteered to organize and stock the CWRU community food pantry.

**DETAIL 1 OF 1****Community Food Pantry Support**

- I volunteered through CWRU's Center for Civic Engagement & Learning
- I supported community service initiatives, including helping stock the CWRU food pantry
- I combined my interests in fitness/health and service by contributing to initiatives focused on increasing food accessibility